

INSPIRED BY COMFORT

MORE DRIVING PLEASURE 2014

**HAPPY
BIRTHDAY**
40 YEARS

WAECO
by Dometic GROUP



Vehicle accessories



Mobile safety solutions



Mobile refrigeration



Mobile electronics



Mobile household devices



Vehicle preheating systems

THE COMPREHENSIVE ACCESSORY RANGE
FOR CARS AND VANS

CONTACT

Any questions?

Perhaps they will arise later, when you have browsed through our comprehensive accessory range for cars and vans, and hopefully fallen in love with one product or another.

“Will it fit my car?” “What does it take to install it?” “Where can I buy it?”
– We will gladly advise you on any question you may have, or tell you your nearest dealer or installer.



Web contact to Dometic WAECO

www.dometic-waeco.com

info@dometic-waeco.com

Always a good link: the Dometic WAECO website where you will find the complete product range. You'll get a clear view of the products along with detailed information. Plus interesting news about our company and the latest special offers. And of course you can order all our catalogues online.

www.dometic-waeco.com



Fresh ideas for your convenience

Pick what you like and add it to your car!

What can be fitted to the vehicle to make it more comfortable and convenient? Where is the best place for a mobile fridge? What does it take to keep everyone in the family happy during the journey? And what can be added to relieve the stress for professional drivers?

These are the sorts of questions we have been finding answers to for 40 years now. Join us as we celebrate the anniversary of our traditional WAECO brand – and discover the results of four decades of joint product development with our customers! You will find test winners like the high-performance compressor coolers in our CFX series (p. 40), handy inverter for mobile power supply (p. 44), and smart technical details such as the tiny yet powerful parking aid

sensors of our MagicWatch 9-series (p. 19). Plus, many well proven comfort solutions to make life on the go more enjoyable.

Welcome to the comprehensive accessory range for cars and vans! Get inspired by our products to make your idea of “More Driving Pleasure” come true.

Your Dometic GROUP Automotive Team



40 years WAECO

Join the party!

.....
In spring 2014 we are going to celebrate the 40th anniversary of our WAECO brand. Join us for the party and look forward to many attractive offers. Just check our website to keep informed.



Direct and simple

Spare parts service and customer support

.....
Ordered today, delivered tomorrow – this goes for all important spare parts for Dometic and WAECO products. Dealers and service partners place their orders via the Dometic GROUP web portal or the Dometic Call Centre. For consumers, many spares will be readily available in the stores as of 2014. For questions concerning the installation, just contact our technical service team by phone or by e-mail.



Comfort factory direct

Original equipment manufacturing

.....
Chances are that your vehicle was already fitted with a Dometic or WAECO product when it left the factory. A 230-volt socket, for instance, or an integrated cooling compartment. As a recognised OEM partner to leading automotive manufacturers we have been designing bespoke car coolers and electronic products for decades.

For everyday or holiday use

More safety and comfort on the road

Take pleasure in your car wherever the road takes you. WAECO offers plenty of accessories to benefit yourself and your vehicle.

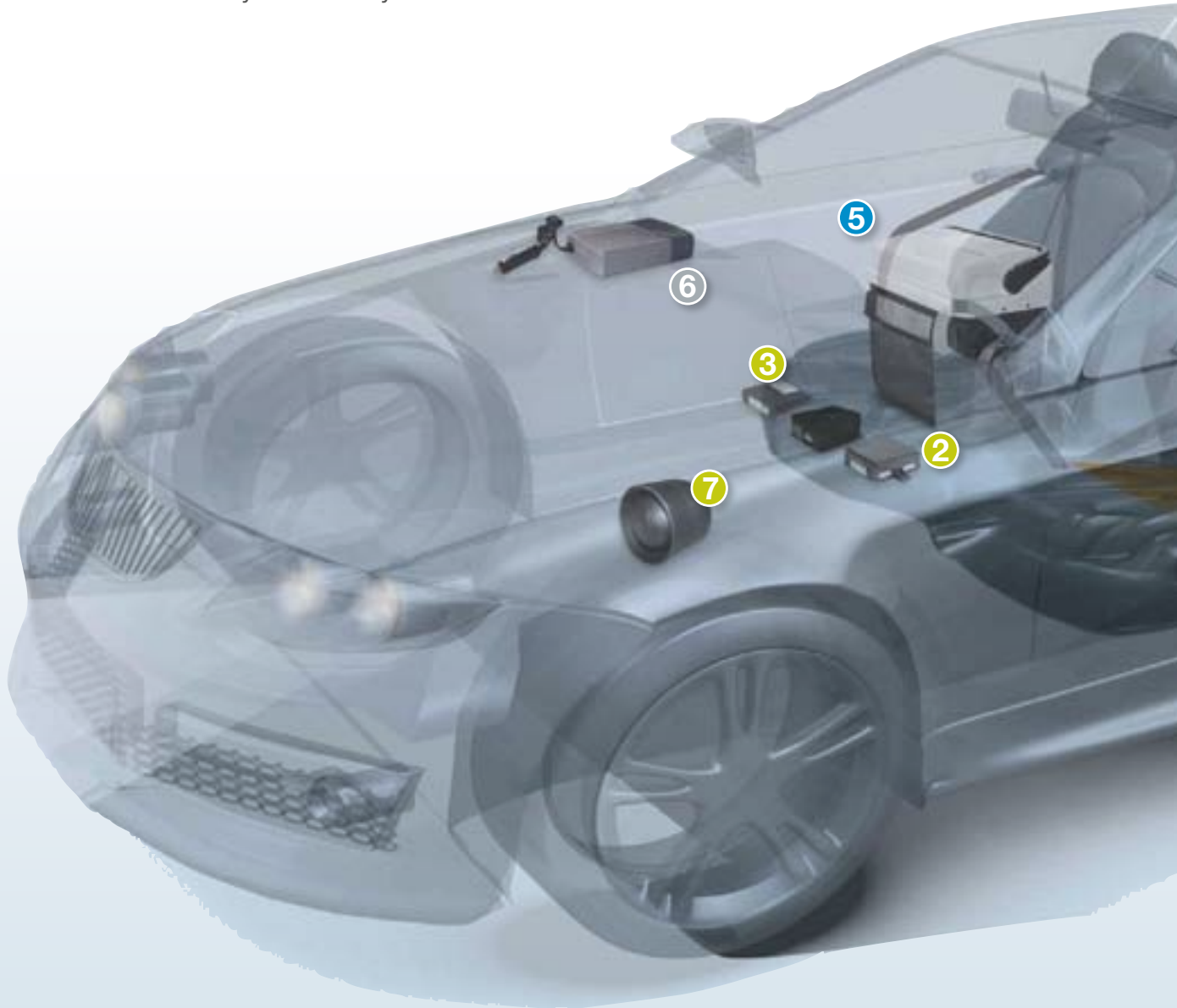

8 – 23

Vehicle accessories

- CAN bus interface
- Car alarms
- Emergency brake light
- Radio remote controls
- Seating comfort
- Cruise controls
- Parking aids

24 – 31

Mobile safety solutions

- LCD reversing video systems
- Moniceiver + rear-view cameras
- Navigation + rear-view cameras

32 – 41

Mobile refrigeration

- Thermoelectric car coolers
- Thermoelectric coolers
- Compressor coolers

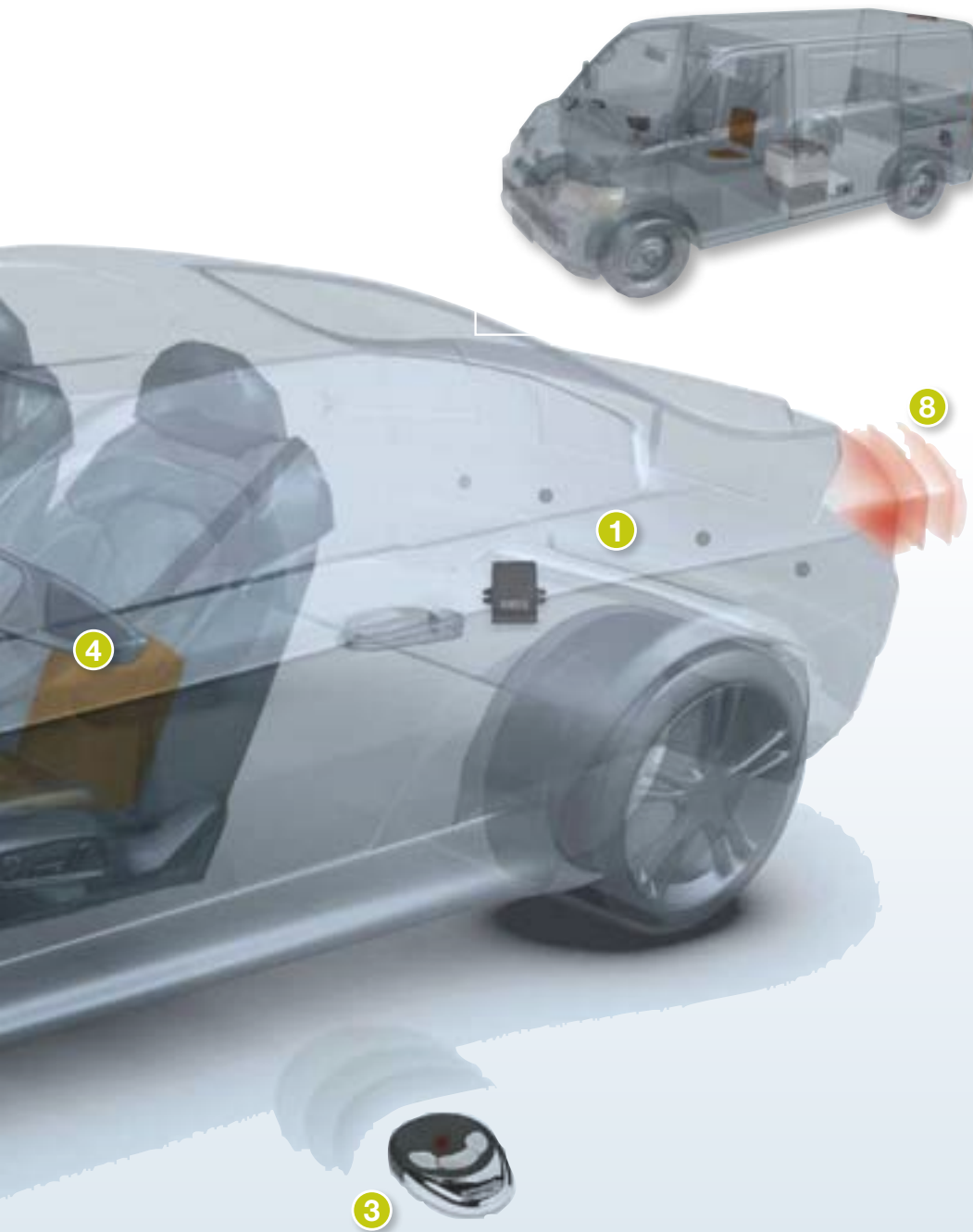

- 1 WAECO MagicWatch**
Parking aid
- 2 WAECO MagicSpeed**
Cruise control
- 3 WAECO MagicTouch**
Radio remote control
- 4 WAECO MagicComfort**
Seating comfort
- 5 WAECO BordBar**
Thermoelectric cooler
- 6 WAECO PocketPower**
Inverter
- 7 WAECO MagicSafe**
Car alarm
- 8 WAECO MagicSafe**
Emergency brake light

42 – 51

Mobile electronics

Laptop charger
Smart inverter
Inverters
Sine wave inverters
Battery care
Charging converters

52 – 55

Mobile household devices

Coffee makers
Electric kettle
Vacuum cleaner

56 – 57

Vehicle preheating systems

DEFA WarmUp



Perfect your car!

Tailor-made accessories for retrofitting

Whatever is lacking can be retrofitted with ease

Do you feel like most vehicle owners? You are quite content with your car, but there's one or two things you'd like to add ... WAECO accessories are here to make your wish come true – quickly, without hassle and at fair prices. We invite you to browse through this catalogue and our website and don't worry if you have picked an analogue accessory while your car has a CAN bus system. The MagicSpeed CBI 150 interface ensures smooth communication between the analogue and digital worlds.

WAECO MagicSpeed CBI 150



3.06

Interface for converting digital CAN bus signals into analogue signals

- 6 analogue output signals
- Automatically identifies the type of vehicle
- Universal product for all types of vehicles

Ref. No. 9101400060



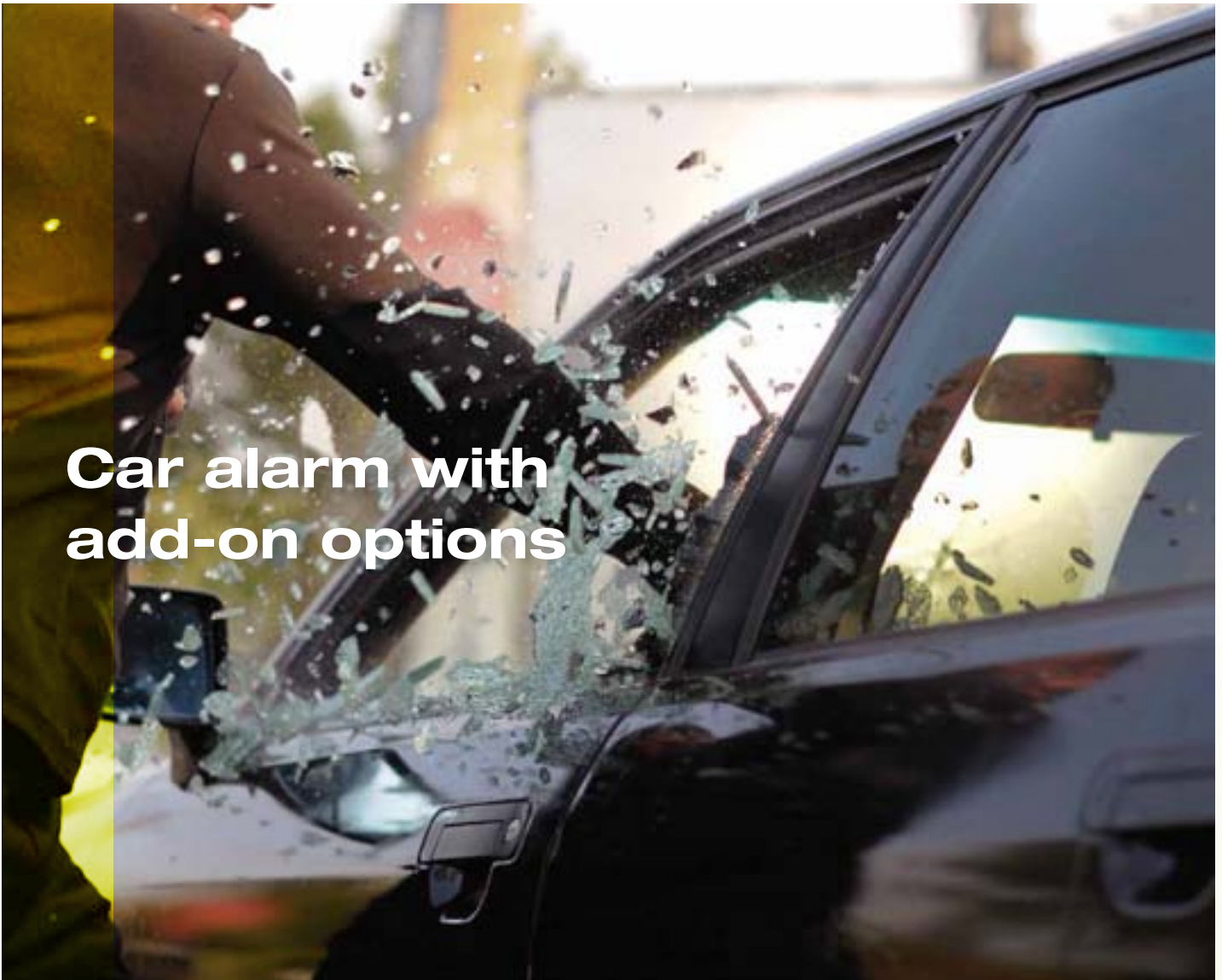

Car alarm with add-on options

The analogue MagicSafe MS 660 universal car alarm is designed as a modular system.

This gives you the opportunity to create your own security concept. You can easily connect additional sensors or functional contact switches to secure roof boxes or bike trailers for example.



WAECO MagicSafe MS 660



3.08

Comfort car alarm

- Monitoring of doors, bonnet, boot
- Ultrasonic interior surveillance (can be switched off)
- Visual alarm via hazard lights

Ref. No. 910160001

Up to 15 radio contact switches can be connected

Scope of delivery:

2 radio hand transmitters, alarm control unit, ultrasonic interior protection, bonnet contact switch, status LED, emergency switch, relay for vehicle horn, pre-configured cable set and fixing material, installation and operating instructions, 2 alarm stickers

Optional extras:

- Siren // Ref. No. 910160008
- Movement sensor // Ref. No. 910160003
- Hand transmitter // Ref. No. 910130009
- Radio contact switch // Ref. No. 910160002
- Gas detector MSG 150 // Ref. No. 9103555858

Effective protection against rear-bumper collisions

Universal emergency brake light for conventional and LED brake lights

Fatal accidents have sadly become part of everyday life. Drivers who don't concentrate or keep too little distance cause most of them. Is there anything you can do about it? Keep a safe distance to the vehicle in front of you – and retrofit the WAECO MagicSafe ABL 100 emergency brake light!

If you need to brake hard because of an emergency or hazardous situation, all three brake lights start flashing at a high frequency. The driver following you is alerted: studies have shown that the reaction time of the person in the vehicle behind is reduced by 0.2 seconds. At a speed of 100 km/h that means the braking distance is actually reduced by five-and-a-half metres!

MagicSafe ABL 100 is a universal system suitable for all vehicles with 12-volt electrics – cars, caravans and vans up to 3.5 tons, conventional and LED brake lights.



WAECO MagicSafe ABL 100



3.08

Emergency brake light

- Installation possible in any position
- Universal use in vehicles with 12-volt electrics (cars, vans up to 3.5 t and motorhomes)
- For vehicles with 3 brake lights
- For conventional and for LED brake lights
- Compliant with regulation ECE R13 and equivalent to regulation ECE R48

Ref. No. 9101600006

Fast installation

Universal use



Unlocking, locking, safely home ...

Remote controls with many extras for convenience

Both remote controls offer the basic functions “unlock” and “lock” in a range up to 20 metres. The car-specific MT 200 is easy to install. It can be fitted even by amateurs and provides high security against copying. MT 400 is a universal remote control with many convenient features. Take the coming home function, for instance, which turns on the dipped headlights for ten seconds so you can see your way safely to your front door.

All comfort functions at a glance:

Auto-relock

Re-locks the car if none of the doors are opened after being unlocked by the hand transmitter.

Interior light

The interior light is switched on from unlocking the doors to starting the vehicle (for a maximum of 30 seconds).

Door locking from inside

Locks the doors while driving, unlocks the doors when the ignition is turned off.

Coming home function

Locking the vehicle activates the dipped headlights so you can see your way safely to your front door.



WAECO MagicTouch MT 200



Radio remote control with car-specific cable set

- Unlocking and locking of the central locking system with blinking hazard lights
- Maximum security against copying through rolling code system
- Ergonomic hand transmitter (20 m range) included
- Can be upgraded to include up to five hand transmitters
- Table of car-specific cable sets at www.dometic-waeco.de/mt200

Ref. No. depending on the vehicle

Optional extra:

Radio hand transmitter for MT 200 // Ref. No. 9101300008



WAECO MagicTouch MT 400



Radio remote control for universal use

- Unlocking and locking of the central locking system with blinking hazard lights
- Many extra functions for enhanced convenience
- Two ergonomic hand transmitter (20 m range) included
- Can be upgraded to include up to five hand transmitters
- No car-specific cable set required, universal system

Ref. No. 9101300007

Optional extra:

Radio hand transmitter for MT 400 // Ref. No. 9101300009

Cool or cosy

Seating
comfort
for hot and
cool days



Sit, don't sweat: the air-conditioned seat cover creates gentle air circulation on the seat and backrest with a pleasant, slightly massaging effect. Two cooling levels are possible.

WAECO MagicComfort MCS 20



3.23

Air-conditioned seat cover made from a breathable cotton-polyester fabric

- Comfortable, stable and safe seating position
- Simple and practical fixing
- Two cooling levels: quick chill and pleasant permanent cooling
- Suitable for cars with side airbags in the seats

Ref. No. 9101700043

Heated seat – relaxed driving

An icy cold seat can easily spoil your mood on a cold day in autumn or winter. Treat yourself and your passenger to cosy warmth from underneath with the two-stage seat heating MagicComfort MH 40.

WAECO MagicComfort MH 40



3.23

Heated seat covers with two heat stages

- Integrated lumbar support pad
- Two easy fastening options
- Two heat stages: pleasant permanent heat or fast heat-up
- Lockable DC plug for a safe contact

MH 40S, black // Ref. No. 9101700023

MH 40GS, grey/black // Ref. No. 9101700024

Fits, warms and protects

Integrated temperature guard



MH40S

MH40GS





Integrated heating

MSH 300: Looks like an original fitting

New press button for easy operation

A warm seat – for one or two

Enjoy luxury-class seating comfort: WAECO MagicComfort MSH 60/601 gets your seat warm in a matter of seconds. As with seat heating integrated in the factory, the heating elements for the seat and the backrest are fitted between the upholstery and the seat cover; the retrofit doesn't alter the shape of the seats. Available for one or two seats.

WAECO MagicComfort MSH 60/601 3.23

Insert seat heater for driver and/or front passenger seat

- Complete sets for one or two seats
- Two heat stages: pleasant permanent heat or fast heat-up
- Integrated temperature guard
- For seats with detachable cover
- **With illuminated switch**

MSH 60 (for two seats) // Ref. No. 9101700025

MSH 601 (for one seat) // Ref. No. 9101700026



Illuminated switch



NEW



Shown in original size

WAECO MagicComfort MSH 300/301 3.23

Carbon insert seat heater for driver and/or front passenger seat

- Cut-to-size carbon heating elements, extremely fast heat-up
- Elegant, ergonomic pressure switch with LED display
- 3 heat stages – from 10 to 70 watts
- RESET when the ignition is turned off
- Four integrated temperature guards

MSH 300 (for two seats) // Ref. No. 9101700034

MSH 301 (for one seat) // Ref. No. 9101700035

Warmth and comfort in record time: Cut-to-size carbon heating

This comfortable retrofit seat heater for the driver and/or front passenger seat heats up extremely quickly. The high-quality carbon elements for the seat and backrest are fitted between the upholstery and the seat cover without altering the shape of the seats.

Driving stress? Not for me!



WAECO MagicSpeed MS 400 / MS 700

3.06

**MS 400 – Comfort cruise control
for vehicles with vacuum servo**

**MS 700 – Comfort cruise control
for vehicles with electric servo**

- Set speed, reset previous speed, fine speed adjustment (tap up/down)
- Adjusts itself automatically to the vehicle parameters
- Choice of two control elements (p. 15, MS-BE3 and MS-BE4)

MS 400 // Ref. No. 9103555827

MS 700 // Ref. No. 9103555851

MS 400 – Universal unit for vehicles with vacuum power source
MS 700 – Universal unit for vehicles without vacuum power source

Universal cruise controls with servo unit

Monotonous roads? Reduced speed limits? MagicSpeed cruise controls let you sit back and relax. MS 400 uses a vacuum servo for linkage to the accelerator cable. MS 700 was designed for vehicles without vacuum power source. Both models automatically adjust to the parameters of your vehicle (self-learn technology).

Universal cruise control for the tighter budget

Driving at a constant, steady speed is easy on the nerves and saves fuel. MagicSpeed MS50 is an inexpensive universal cruise control that works with a vacuum servo. It precisely maintains the set speed without you having to use the accelerator at all.

WAECO MagicSpeed MS 50



3.06

Standard cruise control for universal use

- Functions: set speed and reset previous speed
- Fine speed adjustment (tap up, tap down)
- Attractively designed control element

MS 50 // Ref. No. 9103555828

With resume function

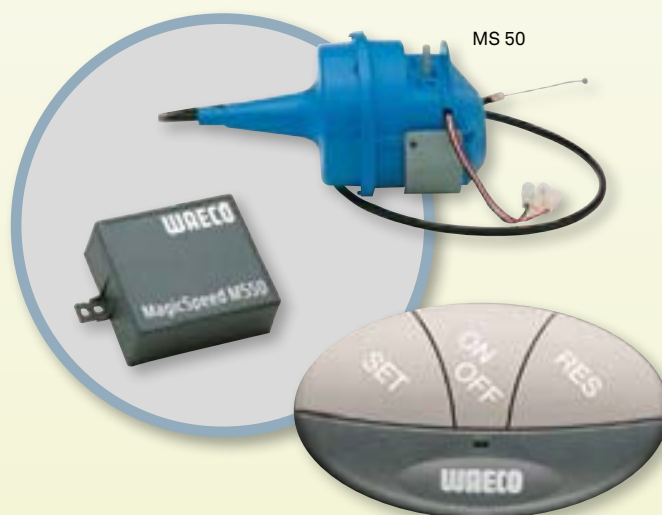

An easy way to keep a steady speed



Vehicle-specific cruise controls

MagicSpeed MS 880 is suitable for almost all vehicles with electronic accelerator, analogue and CAN bus alike. Installation is easy and requires the matching cable set for the vehicle. Enhanced convenience is provided by the speed limiter function.

WAECO MagicSpeed MS 880



3.06

Comfort cruise control with speed limiter function

- Set speed, reset previous speed, fine speed adjustment (tap up/down)
- For vehicles with electronic accelerator
- Designed for specific vehicles

Ref. No. 9101400069

Accessory

Cable set // Ref. No. vehicle-specific

Optional extras

MagicSpeed CBI 150

Digital/analogue translator // Ref. No. 9101400060

OBD-II plug (PIN 6 and 14 occupied) // Ref. No. 9101400067

Signal amplifier // Ref. No. 9103555857

Complete sets specially for Fiat Ducato

Ducato 250, 2006 to 2011 incl. cable set, control element, pre-programmed software // Ref. No. 9101400065

Ducato 250 3.0 TDi, 06/2011 incl. cable set, control element, pre-programmed software // Ref. No. 9101400066



WAECO MagicSpeed Accessories

3.06

1 Control element to be fitted on the dashboard

- Easy installation
- ON/OFF switch, fine speed adjustment

MS-BE3 // Ref. No. 9103555852

2 Control lever to be fitted on the steering column

- Attractive design, looks like an original fitting
- ON/OFF switch with status indication, fine speed adjustment

MS-BE4 // Ref. No. 9103555853

3 Control lever to be fitted on the steering column (for MS 880 only)

- Cross control (push/pull/up/down)
- Memory for two speeds
- With "Cancel" function

MS-BE7 // Ref. No. 9101400068

3



2



1





Parking aids by WAECO

Popular retrofit systems

Reliable, inexpensive, fitted in no time at all!

Parking spaces are always tight, and hardly any vehicle is really easy to park. It's even worse when someone honks at you from behind ... Luckily, there are such things as parking aids. They assist you in tricky situations and prevent those annoying bumps and scrapes.

If your vehicle was has no original parking aid, **you can easily have one retrofitted**. The WAECO range gives you a choice of **nine well-proven systems** – parking aids for the **rear, front or both**. WAECO sensors are extremely small and **easy to fit**. The whole package including the installation will cost you far less than the vehicle manufacturer's retrofit solutions.

Three system versions

The matching parking aid for every customer and for every vehicle

The complete solution
Tiny sensors for the front and rear



The front and rear bumpers are fitted with the smallest sensors available in the market. This gives you maximum safety and flawless installation results. Independent tests have shown that MagicWatch 9-series parking aids exceed the performance of most serial systems by far. You can pick a "classic" hard-wired system, or opt for an easy-to-install wireless model.

Page 19

The classical rear solution
Popular retrofits



A total of five MagicWatch rear systems cover almost all imaginable applications and requirements. From cars to vans and light trucks, from budget to premium. With Digital Signal Memory or the option to shift the stop line. If you don't find what you want here, check out our complete systems!

Pages 20 – 22

The front solution
Wireless or hard-wired



For customers wishing to secure their vehicles towards the front we offer two MagicWatch front systems. The wireless WPS 900F is based on the ultra-small sensors of the 9-series and is fitted in a flash. If you prefer a hard-wired model, opt for the MWE 890, which can be used stand-alone or complementary to an existing rear system.

Page 23

	FRONT-AND-REAR SYSTEMS		REAR SYSTEMS					FRONT SYSTEMS	
3.07	MWE 9008	WPS 910	MWE 820	MWE 860	MWE 9004	MW 650	MWE 650	MWE 890	WPS 900F
Parameter Programming System (PPS)	●	●	–	–	●	–	–	–	●
Option to shift the stop line	●	●	–	–	●	●	●	–	●
Integrated CAN bus interface	–	●	–	–	–	–	–	–	●
Range Stop zone	Rear: approx. 10 – 30 cm Front: approx. 10 – 25 cm	Rear: approx. 10 – 30 cm Front: approx. 10 – 25 cm	approx. 10 – 40 cm	approx. 10 – 40 cm	approx. 10 – 30 cm	approx. 10 – 30 cm	approx. 10 – 30 cm	approx. 10 – 35 cm	approx. 10 – 25 cm
Measuring range	Rear: approx. 30 – 180 cm Front: approx. 25 – 95 cm	Rear: approx. ca. 30 – 180 cm Front: approx. 25 – 95 cm	approx. 40 – 160 cm	approx. 40 – 160 cm	approx. 30 – 180 cm	approx. 30 – 250 cm	approx. 30 – 250 cm	approx. 35 – 75 cm	approx. 25 – 95 cm
Acoustic warning function	●	●	●	●	●	●	●	●	●
Visual warning function Display	–	LED display	–	LED display	LED display with distance indication (optional)	LED display with distance indication	LED display with distance indication (optional)	LED display (optional)	LED display
Radio mute control	●	–	●	●	●	–	–	●	–
Suitable for tow-bar vehicles	●	●	●	●	●	●	●	–	–
Activation via	Rear: Reverse gear Front: speed signal	Rear: Reverse gear Front: speed signal or switch	Reverse gear	Reverse gear	Reverse gear	Reverse gear	Reverse gear	Speed signal optional switch	Speed signal or switch
Sensors	8 built-in sensors	8 built-in sensors	4 built-in sensors	4 built-in sensors	4 built-in sensors	4 sub-mounted sensors	4 built-in sensors	4 built-in sensors	4 built-in sensors
Visible sensor area	18 mm	18 mm	25 mm	25 mm	18 mm	29 mm	29 mm	25 mm	18 mm
Cut-out for sensor	18 mm	18 mm	22 mm	22 mm	18 mm	24 mm	24 mm	22 mm	18 mm
For cars/vans	●	●	●	●	●	●	●	●	●
For light trucks	–	–	–	–	–	●	●	–	–
Page	19	19	20	20	21	22	22	23	23
Ref. No.	9101500055	9101500020	9101500040	9101500041	9101500054	9103555875	9103555886	9101500042	9101500019

Front system

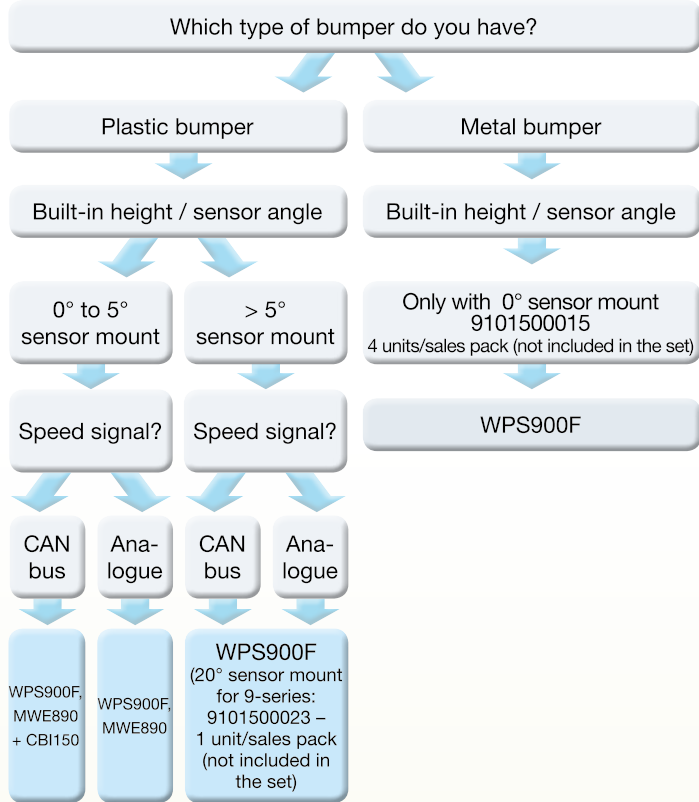

Rear system

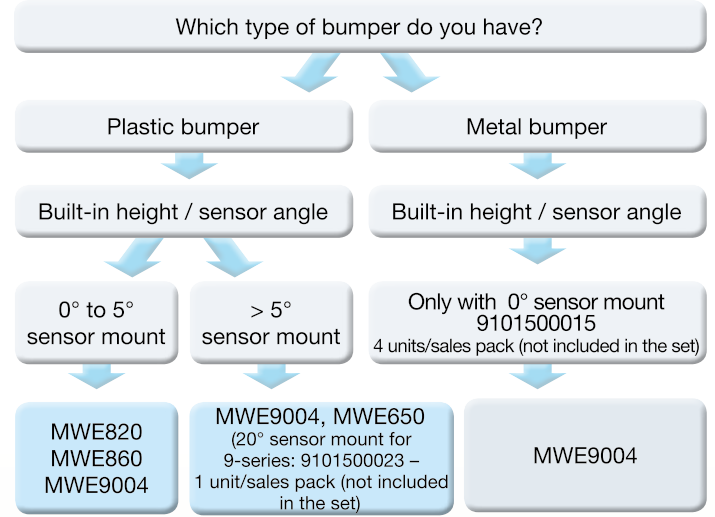

Note:

It can be impossible, in rare cases, to tap the reverse gear signal at the reversing lights. This can be the case if you have a vehicle with LED reversing lights. In these vehicles the signal has to be tapped elsewhere (e.g. at the fuse box), or provided by means of a CAN-bus adapter (CBI 150).

Complete system

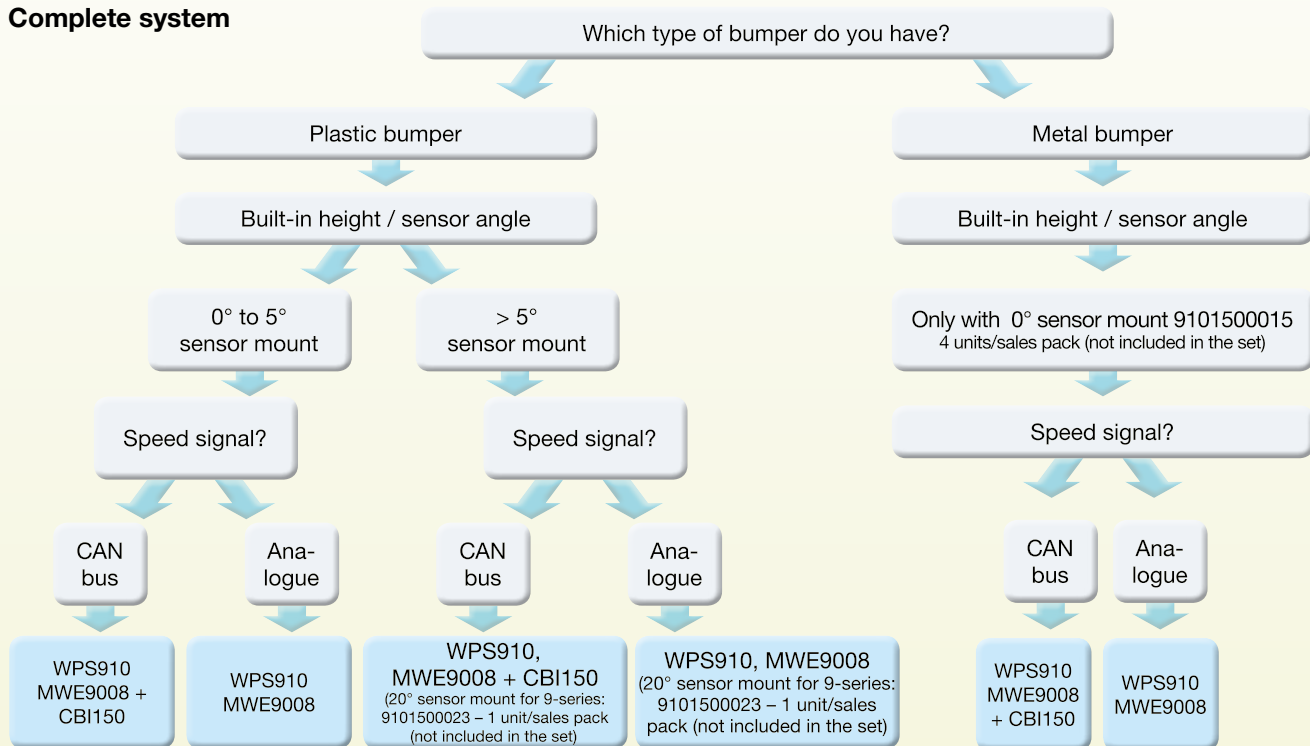

Note:

- It can be impossible, in rare cases, to tap the reverse gear signal at the reversing lights. This can be the case if you have a vehicle with LED reversing lights. In these vehicles the signal has to be tapped elsewhere (e.g. at the fuse box), or provided by means of a CAN-bus adapter (CBI 150).

- Have the sensors painted beforehand (colour code)

To find out which types of vehicles are compatible with a CAN-bus link, please check the corresponding list on our website:

WPS: http://www.waeco.com/pdf/MagicSpeed_WPS_900F_WPS910_en.pdf
CBI: http://www.waeco.com/pdf/MagicSpeed_CBI_150_en.pdf



Safety for rear and front

Well proven complete solution

Four built-in sensors each on the front and rear make sure nothing can go wrong when you park your car.

MagicWatch MWE 9008 is a well proven hard-wired parking aid. It exceeds the performance of many factory-fitted systems and guarantees flawless installation results. **A special feature is the option to shift the stop line.**

WAECO MagicWatch MWE 9008  **3.07**

Parking aid for cars, 8 built-in sensors (ø 18 mm)

- Complete solution for front and rear
- For vehicles up to 2.20 m wide
- Parameter Programming System (PPS)



Ref. No. 9101500055

Installation results like with an original fitting
Supplied with core bit

Optional extras

- 1.5 m extension cable for sensors // Ref. No. 9103555747
- MagicSpeed CBI 150, Digital/analogue translator // Ref. No. 9101400060
- Punching tool for 18 mm sensors // Ref. No. 9101500013
- Punching tool for 22 mm sensors with 10° mount // Ref. No. 9101500024
- ON/OFF switch for front parking aid // Ref. No. 9103555920



Painted WAECO sensor – flawless installation result

Radio-based complete system

The wireless parking aid WPS 910 is ideal for parking with perfection. Featuring the same elegant sensors like the MWE 910, it is even faster to install. The wireless transmission of the control signals **saves you the effort of having to lay cables across the length of the vehicle.** There's no need to drill into the bulkhead either, because the two robust control units are fitted straight in the bumpers.

WAECO MagicWatch WPS 910  **3.07**

Wireless parking aid for cars, 8 built-in sensors

- Radio-based complete solution for front and rear
- For vehicles up to 2.20 m wide
- Option to shift the stop line
- Integrated CAN bus interface for the speed signal (analogue connection is also possible)



Ref. No. 9101500020

Flawless installation – looks like an original fitting

Optional extras

- Punching tool for 18 mm sensors // Ref. No. 9101500013
- Punching tool for 22 mm sensors with 10° mount // Ref. No. 9101500024





Low-cost rear parking aids for cars

With or without LED display

Reliable “rear protection” for your car does not have to be expensive. Our two new MagicWatch parking aids are the best proof. Both are suitable for vehicles up to 2.20 m wide and feature four sensors and an acoustic warning system. The MWE 860 provides the extra comfort of visual distance indication on an elegant LED-display.



WAECO MagicWatch MWE 820



3.07

Rear parking aid for cars, 4 built-in sensors

- Activation via reverse gear
- Acoustic warning function, range: approx. 10 – 160 cm
- Sensor sensibility can be set in 3 steps
- Can also be used on vehicle with tow-bars

Ref. No. 9101500040

Entry-level-price model

Built-in sensors for a perfect finish



WAECO MagicWatch MWE 860



3.07

Rear parking aid for cars, 4 built-in sensors and LED display

- Activation via reverse gear
- Acoustic and visual warning function, range: approx. 10 – 160 cm
- Sensor sensibility can be set in 3 steps
- Can also be used on vehicle with tow-bars

Ref. No. 9101500041

With elegant LED display

Extra-small, paintable built-in sensors

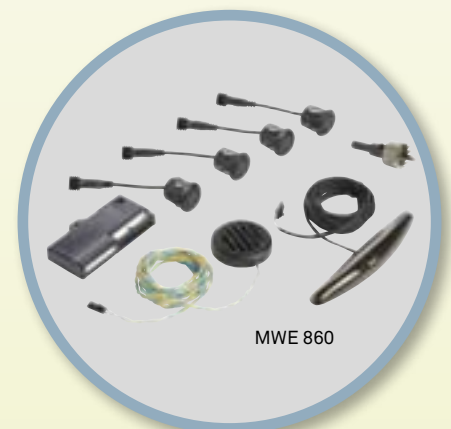



Rear parking aid with small sensors and optional colour display

Let your MagicWatch parking aid warn you before you crash into an object. The **new MagicWatch MWE 9004 features the tiny built-in sensors of the 9-series**, which are only 18 mm in diameter and won't miss a thing. Painted in the colour of the vehicle, they look like an original fitting. Acoustic warning is integrated as standard and if you want to have visual information too, order the optional digital colour display, or the new LED display.

WAECO MagicWatch MWE 9004



3.07

Rear parking aid for cars, 4 built-in sensors

- Activation via reverse gear
- Acoustic warning function
- Range: approx. 10 – 180 cm
- Option to shift the stop line



Ref. No. 9101500054



Option: The digital colour display indicates the distance with graphics and numbers



Optional: beautiful LED display

Optional:

Display for visual distance indication (12 volts)
Ref. No. 9101500002

NEW: LED display // Ref. No. 9101500062

Punching tool for 18 mm sensors // Ref. No. 9101500013

Punching tool for 22 mm sensors with 10° mount // Ref. No. 9101500024

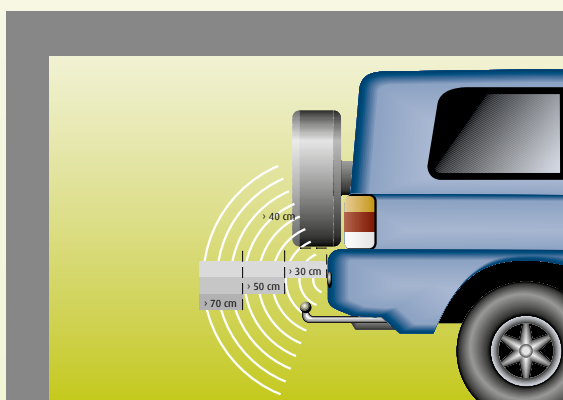

Variable stop line

The parking aid sensors are located at the rear bumper, but there's a tow-bar or spare tyre protruding beyond the bumper? No problem whatsoever, the MagicWatch parking aids MWE 9004, MWE 9008, WPS 900F and WPS 910 will take account of such "extras". With these systems you can simply shift back the stop line by up to 40 cm.



Parking like a professional

Rear systems for trucks up to 7.5 t

The parking aids MW 650 and MWE 650 **have been specifically designed for larger (utility) vehicles**. Their distinguishing features: a large range of 250 cm, acoustic and visual warning functions, Digital Signal Memory (DSM function), free voltage supply from 10 – 32 volts, splash-proof components, extra-long sensor lines. The MW 650 is easy to install, the sensors are mounted under the rear bumper. The MWE 650 comes with built-in sensors for a more stylish finish.

WAECO MagicWatch MW 650



3.07

Rear parking aid for trucks, 4 sub-mounted sensors

- Designed for larger vehicles (12 and 24 volts)
- Acoustic and visual warning function
- Digital Signal Memory (DSM)
- Range: approx. 10 – 250 cm

Ref. No. 9103555875

Sub-mounted system: fitted in 2 – 3 hours!

WAECO MagicWatch MWE 650



3.07

Rear parking aid for trucks, 4 built-in sensors

- Designed for larger vehicles (12 and 24 volts)
- Acoustic and visual warning function
- Digital Signal Memory (DSM)
- Range: approx. 10 – 250 cm

Ref. No. 9103555886

Installation time: 3 – 4 hours

Visual warning function on both systems

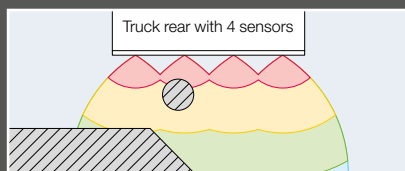

Left: digital display shows distance at centimetre accuracy

Right: 4-colour LED displays distance for each sensor

A single glance is enough to know which of the four sensors is closest to an obstacle.

Ideal for light trucks up to 7.5 t

MWE 650
The display unit is firmly installed in the truck cabin

MW 650
Easy installation with four sensors integrated in the rear bumper

MW 650
Easy installation with four sensors mounted to underside of the rear bumper

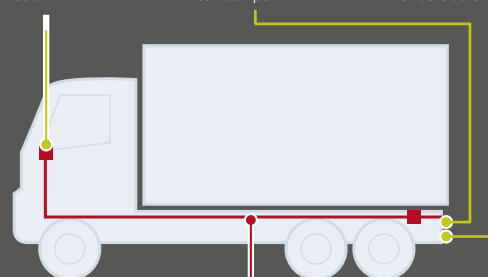

Hard-wired signal transmission from the base unit to the receiver



'Extra pair of eyes' for the front

Punching tool

WAECO MagicWatch MWE 890 3.07

Front parking aid for cars, 4 built-in sensors

- Activation via speed signal, reverse gear (timer) or switch (optional)
- Acoustic (and optional visual) warning function
- Optimised range of approx. 10 – 75 cm

Ref. No. 9101500042

Optional extras

- LED display // Ref. No. 9101500045
- External switch // Ref. No. 9101500049

Front parking aid for retrofitting

Do you want to supplement your rear parking aid to get all-round protection for your car? Then you should opt for one of our optimised-range front systems – e.g. the new, hard-wired MWE 890. You can hear (and see on the optional LED display) how close you are to an object, and when it is time to stop.

Wireless front system

There's no need to drill through the bulkhead to install this system, thanks to the radio-based communication between the control unit and the operating element. The optional punching tool can be used to fit the tiny 18 mm sensors into the bumper with great results. WPS 900F has a range of 25 – 95 cm, which is perfect for a front parking aid. The system gives you the option to shift the stop line and is fitted in record time.

WAECO MagicWatch WPS 900F 3.07

Wireless front parking aid for cars, 4 built-in sensors

- Activation via speed signal, reverse gear (timer) or switch
- Loudspeaker with LED display (acoustic and visual warning)
- Optimised range of 10 – 95 cm
- Option to shift the stop line
- Integrated CAN bus interface for the speed signal (analogue connection is also possible)



Ref. No. 9101500019

Optional extras

- Punching tool for 18 mm sensors // Ref. No. 9101500013
- Punching tool for 22 mm sensors with 10° mount // Ref. No. 9101500024

The optional punching tool for 9-series sensors makes it easier and faster for you to fit the sensors in the bumper.



Thanks to a special punching method the paint around the hole will not be damaged, cracked or chipped.



For an aesthetically pleasing finish, paint the sensors in the colour of the bumper.





For a clearer view

Reversing video systems from WAECO

A far-sighted investment

Camera-monitor systems for cars and vans

Reversing accidents can happen quickly. Flower pots, fence posts, trees, tight parking spaces – the danger of hitting something is everywhere and that's when things get expensive.

A WAECO PerfectView reversing video system can spare you a lot of trouble and money. The investment will have paid for itself the first time damages are avoided. On the following pages we show you some of our most popular systems for cars, plus two special solutions. All of them are based on the same, high-quality, digital 5" LCD monitor, the camera types vary.

Newcomer to the range: WAECO moniceiver for important information and good entertainment.

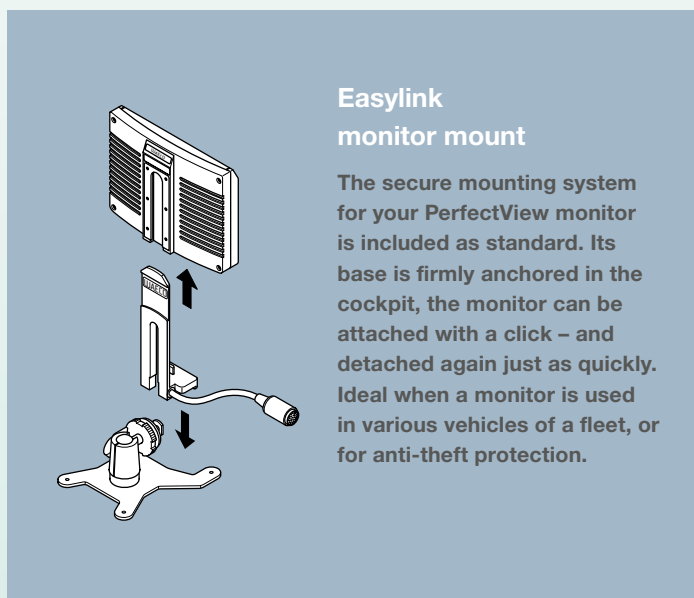









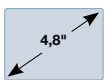

Easylink monitor mount

The secure mounting system for your PerfectView monitor is included as standard. Its base is firmly anchored in the cockpit, the monitor can be attached with a click – and detached again just as quickly. Ideal when a monitor is used in various vehicles of a fleet, or for anti-theft protection.

Overview of LCD reversing video systems

NEW!

	4.8"/122 mm	4.8"/122 mm	4.8"/122 mm	4.8"/122 mm	7"/178 mm
System	RVS550	RVS580	RVS530	RVS560	RVS718
Ref. No.	910190009	910190020	910190034	910190057	910190047
Monitor	M5L	M5L	M5L	M5L	M7LS
Digital LCD technology					
→ Fast image build-up → Stable monitor image					
					
Operating voltage	12 to 30 volts DC	12 to 30 volts DC	12 to 30 volts DC	12 to 30 volts DC	11 to 16 volts DC
Power input	10 watts	10 watts	10 watts	10 watts	6 watts
Resolution	235,000 pixels	235,000 pixels	235,000 pixels	235,000 pixels	337,000 pixels
LED background illumination	●	●	●	●	●
Video standard	NTSC/PAL auto	NTSC/PAL auto	NTSC/PAL auto	NTSC/PAL auto	NTSC/PAL auto
Number of camera inputs	3 with signal recognition	3 with signal recognition	3 with signal recognition	3 with signal recognition	2
Day/night dimmer	automatic via LDR	automatic via LDR	automatic via LDR	automatic via LDR	—
Mirror function	can be set	can be set	can be set	can be set	can be set
Loudspeaker	●	●	●	●	●
Vibration resistance	5 g	5 g	5 g	5 g	5 g
Temperature range	-20 to +70 °C	-20 to +70 °C	-20 to +70 °C	-20 to +70 °C	-20 to +65 °C
Camera	CAM50C	CAM80CM	CAM30CK	CAM29BK	CAM18
					
Picture sensor CCD chip	1/4" CCD	1/3" CCD	1/4" CCD	1/4" CMOS	1/4" CCD
Resolution	270,000 pixels	270,000 pixels	270,000 pixels	270,000 pixels	270,000 pixels
Picture angle horizontal/vertical/diagonal	90°/70°/120°	100°/72°/145°	90°/70°/120°	102°/73°/150°	120°/90°/70°
Light sensitivity	< 0.5 lux or 0 lux with LED	< 0.5 lux or 0 lux with LED	< 0.5 lux or 0 lux with LED	< 1 lux	< 1 lux or 0 lux with LED
Video standard	PAL	PAL	PAL	PAL	PAL
Electronic brightness adjustment	●	●	●	●	●
IR LED technology for optimum night-time vision	●	●	●	—	●
Integrated microphone	●	●	●	—	●
Heating	●	●	—	—	—
Motor-operated camera shutter	—	●	—	—	—
Vibration resistance	6 g	6 g	6 g	6 g	6 g
Type of protection	IP 69K	IP 68	IP 68	IP 68	IP 68
Mirror function	can be set	can be set	can be set	fixed mirrored	can be set
Temperature range	-20 to +65 °C	-20 to +65 °C	-20 to +65 °C	-20 to +65 °C	-20 to +65 °C
Applications					

The camera can see more when reversing

The rear-view classics

Complete systems with a compact or shutter camera

If there's room to fit a small camera on the rear of your vehicle, one of our well proven complete systems is just the right thing. The PerfectView RVS 550 combines the practical 5" LCD monitor with a tiny, heated colour camera enclosed in extra-low-profile housing. The same monitor is used on the RVS 580, which comes with a camera fitted with a motor-operated shutter to keep the camera lens clean. The wide picture angle of 145° comes in very handy while reversing.



WAECO PerfectView RVS 550

WAECO PerfectView RVS 580

With motor-operated shutter (RVS 580)

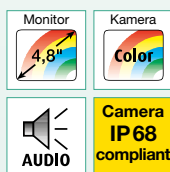

WAECO PerfectView RVS 550



3.19

Reversing video system with 4.8" LCD monitor and colour camera

- Compact, heated camera with extra-low-profile housing
- Infrared LED for enhanced night-time vision
- Detachable LCD monitor with LED background illumination
- Signal recognition for a second camera (e.g. on a trailer)

Ref. No. 9101900009

High-quality LCD system at a favourable price

WAECO PerfectView RVS 580



3.19

Reversing video system with 4.8" LCD monitor and colour shutter camera

- Compact camera with motor-operated shutter
- Infrared LED for enhanced night-time vision
- Detachable LCD monitor with LED background illumination
- Signal recognition for a second camera (e.g. on a trailer)

Ref. No. 9101900020

Monitor with USB charger port for MP3 players etc.



Custom solutions for panel vans

Mobile safety solutions

WAECO PerfectView RVS 530



3.19

Reversing video system with 4.8" LCD monitor and colour ball camera

- Specially designed for panel vans
- Compact ball camera in roof-mount housing
- Detachable LCD monitor with LED background illumination
- Signal recognition for a second camera (e.g. on a trailer)

Ref. No. 9101900034

WAECO PerfectView RVS 560



3.19

Reversing video system with 4.8" LCD monitor and colour cylinder camera

- Cylinder camera in brake light console
- Specially designed to be fitted on the original brake light of Fiat Ducato X250, Citroën Jumper, Peugeot Boxer
- Detachable LCD monitor with LED background illumination

Ref. No. 9101900057

Camera with an extra-wide picture angle of 150°



WAECO PerfectView RVS 530

WAECO PerfectView RVS 560

Supplied without brake light

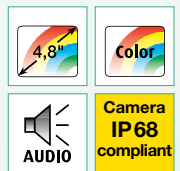

Audio not available for RVS 560

PerfectView RVS 560 with brake light console

The console integrating the camera is quickly fitted to the original brake light. A smart way to overcome the tricky mounting conditions on the Fiat Ducato X250 and its sister models.



No space at the rear? Use the roof or brake light!

Most panel vans don't have a suitable place on the rear to fit a camera. Not to worry, WAECO offers two ingenious alternatives. For the PerfectView RVS 530 reversing video system we integrated a small ball camera into a roof-mount housing which slightly extends beyond the vehicle rear. The PerfectView RVS 560, designed for Fiat Ducato X250, uses a camera enclosed in a console to be fitted on the original brake light.



All ears and all eyes
 Entertainment and
 reversing safety combined

WAECO's well proven reversing video systems provide safety at its best.

The new WAECO moniceiver adds good entertainment.

Watch films, listen to music and the traffic news: the new WAECO moniceiver combines the functions of a car radio and those of a DVD/VDC/CD/MP3/WMA player. When a reversing camera is added, it also makes manoeuvring safer.

NEW! WAECO PerfectView MC 402

Moniceiver with 6.2" 2 DIN monitor, touch-screen display, lots of multimedia functions, input for a reversing camera

Ref. No. 9102100024

Optional extras:

WAECO PerfectView installation frames

Frame for FIAT Ducato,

Ref. No.: 9102200106

Frame for Mercedes-Benz Sprinter,

Ref. No.: 9102200109

Frame for Ford Transit,

Ref. No.: 9102200120

Frame for Iveco Daily,

Ref. No.: 9102200127

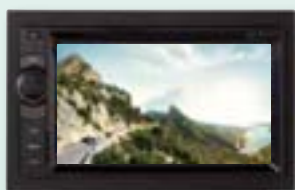

NEW! WAECO PerfectView MC 460

Moniceiver incl. brake light console with colour cylinder camera for FIAT Ducato X250 from 2006

Moniceiver + CAM 29BK NAV

Ref. No. 9101900071



Supplied without brake light



NEW
Moniceiver for
panel vans

What do you do if your vehicle has no suitable place on the rear to fit a rear-view camera? Not to worry, WAECO offers two smart alternatives: compact cameras to be fitted on the brake light or integrated in a roof-mount housing. Both are available as a complete set or individual component to complement an existing navigation system.

NEW! WAECO PerfectView MC 430

Moniceiver incl. roof-mount housing with colour ball camera for panel vans

Moniceiver + CAM 30CK NAV

Ref. No. 9101900073



**Safe manoeuvring
without a big price tag:**
Complete system with
CMOS camera

This provides a really impressive performance at a low price! Our new entry-level-price model WAECO PerfectView RVS 718 will outwit the blind spot of your vehicle, and warn you about treacherous obstacles. It is comprised of a colour CMOS camera and a flat, easy-to-use 7" LCD monitor. The camera is mounted in an extremely compact housing, which is inconspicuous and elegant at the same time. As a ball camera it is highly flexible and can be aligned as required. Six integrated IR LEDs provide better vision in the dark.

WAECO PerfectView RVS 718

3.19

Reversing video system with a 7" LCD monitor and a compact colour CMOS camera

- CMOS colour camera (PAL) with LED
- LEDs for improved night vision
- Microphone
- Ball camera for flexible alignment
- 7" colour LCD monitor
- Loudspeaker
- Slim housing, approx. 26 mm in depth
- Operating voltage 12 volts
- LED background illumination



Ref. No. 9101900047

High-quality LED system at a low price



ARRIVE SAFE AND SOUND NAVIGATION AND REVERSING VIDEO SYSTEMS

Blaupunkt navigation systems and
WAECO rear-view cameras are an unbeatable team.

NEW!
Silk Vision Display
 Free map updates
 for 12 months



NEW! Blaupunkt New York 835W EU **Multimedia navigation system**

- 6.2" Silk Vision TFT display – for excellent readability
- Navigation throughout Europe
- Maps for 35 countries in Europe
- 12 months of free map updates
- Prepared for DAB receiver

Optional extras:

WAECO PerfectView installation frames

- Frame for FIAT Ducato,
Ref. No.: 9102200106
- Frame for Mercedes-Benz Sprinter,
Ref. No.: 9102200109
- Frame for Ford Transit,
Ref. No.: 9102200120
- Frame for Iveco Daily,
Ref. No.: 9102200127

As a leading supplier of mobile video systems we have combined multimedia navigation systems from Blaupunkt with rear-view cameras specially designed for panel vans. The result: integrated comfort solutions for navigation and reversing that use the navigation monitor for both functions.

NEW! WAECO PerfectView **NAV 760EU**

Blaupunkt navigation system New York 835W EU incl. brake light console with colour cylinder camera for FIAT Ducato X250

Navigation system + CAM 29BK NAV

Ref. No. 9101900066

BLAUPUNKT



Supplied without brake light



Our Tip!

**Blaupunkt Philadelphia 835 EU
multimedia navigation system for VW T5**

- Navigation system with 7" TFT display
- 12 months of free map updates
- Promobil caravan site software
- Prepared for DAB receiver

Mobile safety solutions

FOR YOUR SAFETY

Navigation + reversing video systems

- All complete systems are specially designed for panel vans
- Rear-view cameras are also available individually

**NEW! WAECO PerfectView
NAV 718PH**

Blaupunkt navigation system Philadelphia 835 EU
incl. colour camera

Navigation system + CAM 18NAV

Ref. No. 9101900063



**NEW! WAECO PerfectView
NAV 750PH**

Blaupunkt navigation system Philadelphia 835 EU
incl. colour camera

Navigation system + CAM 50NAV

Ref. No. 9101900064



In order to offer a matching system for all mounting conditions we have combined two Blaupunkt navigation systems with four different camera models from the PerfectView range. The software provides maps for 35 European countries – free updates for 12 months included.

**NEW! WAECO PerfectView
NAV 730EU**

Blaupunkt navigation system New York 835W EU incl. roof-mount housing with colour ball camera for panel vans

Navigation system + CAM 30CK NAV

Ref. No. 9101900067





Car coolers from WAECO

Two refrigeration technologies for more freshness on board

Low-cost and versatile

Cooling and deep-freezing

Thermoelectrics

Thermoelectric coolers by WAECO are especially lightweight and easy to transport. They can be used in different vehicles and environments without any problem. Many thermoelectric coolers can heat as well.

- **Lightweight and compact**
- **Easy to carry**
- **Cooling capacity up to 30°C below ambient temperature**
- **Can be switched to heating mode (depending on the model)**
- **For 12/24 DC as well as 230 volts AC (depending on the model)**
- **Wear-resistant and maintenance-free**
- **Favourably priced**

Compressor cooling

Compressor coolers by WAECO provide excellent cooling and deep-freezing, even at extreme outside temperatures. The cooling performance ranges up to -22°C , depending on the model. The boxes are quiet and energy-saving. They operate on any DC power source, some of them even on any mains system.

- **Powerful, intensive cooling regardless of the outside temperature**
- **Deep-freezing up to -22°C (depending on the model)**
- **Minimal energy consumption**
- **For 12/24 volts DC and 100 – 240 volts AC (depending on the model)**
- **Ideal for solar operation**
- **Reliable and durable**



Our tip!

230-volt connection with low-priced mains adapters



Fixed for cooling:

A safe place in the vehicle

Different cars, different coolers, different customer needs – we had all of these in mind when creating our fastening solutions. Pick what suits you best. Your local dealer and the Dometic WAECO team are happy to help.

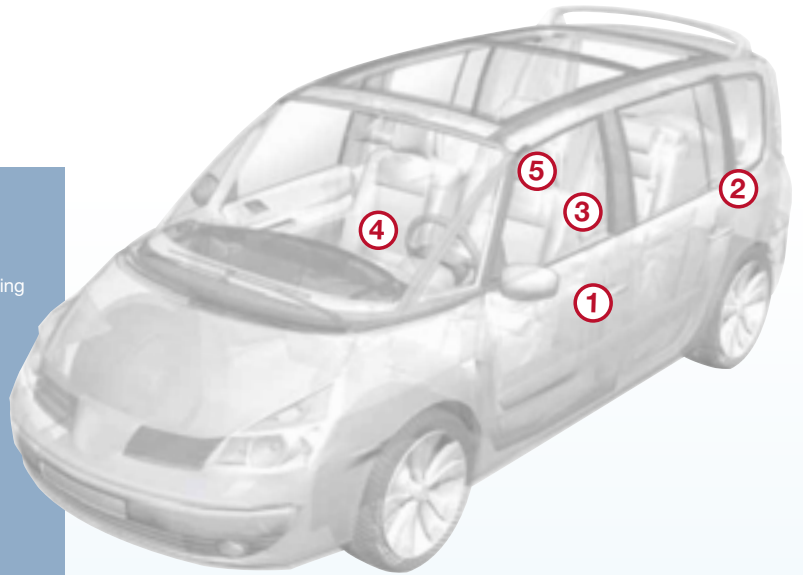

① Simple “push-in” fastening

Small coolers like the TF 08 or TF 14 can be pushed between the front passenger seat and the backseat – a simple and effective means of keeping your cooler in place.

For example:

WAECO BordBar TF 08



Page 35

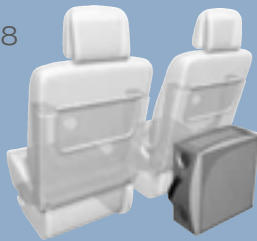

② Simply stored in the boot

If the boot is filled with various items anyway, safe transport can normally be ensured by placing coolers amidst the luggage – without any additional means of fastening.

For example:

WAECO TropiCool TC 07



Page 37



③ ISOFIX fastening

Many vehicles are supplied with ISOFIX points for anchoring child seats on the rear bench. Using this well-established technology, WAECO has designed the TE 21 ISO car cooler for ISOFIX fastening.

For example:

WAECO BordBar TE 21 ISO



Page 35



④ Belt fastening on a seat

The belt is either guided along the lid hinges or across the front of the cooler. For front passenger seat or back seat.

For example:

WAECO CoolFreeze CDF 11



Page 38



⑤ Fastening between the seats

In three-seat rows the cooler can also be fitted in place of the middle seat and secured in place with the WAECO universal fixing kit. Fits CDF 25, CFX 35 and CFX 40.

For example:

WAECO CoolFreeze CDF 25



Page 39





Up to 18 – 30°C below ambient temperature, depending on the model



Up to 65°C in the heating mode



Active Battery Security



12/230 volts

Cost effective cooling!

Shopping, picnic, holiday, beach – the versatile WAECO BordBar AS 25 deals with any outing effectively. High-performance thermoelectrics at a bargain price, ready for use on 12 or 230 volts. Plus: 20 litres capacity, a sturdy housing with a textile skin, a shoulder strap, diverse outside pockets.

WAECO BordBar AS 25

4.08

Thermoelectric car cooler with DC/AC auto switch

- 20 litres capacity, ready for connection to 12/230 volts
- Cooling up to 18°C below ambient temperature
- Room for 2-litre bottles standing upright
- Two zip-closure pockets, one net pocket, one cable compartment

Ref. No. 9105302816

Box and bag attractively combined
Velcro fasteners for a firm hold in the car



A++

Energy class



WAECO
BordBar AS 25



WAECO
BordBar TB 08

WAECO
BordBar TB 15



WAECO BordBar TB 08

4.08

Thermoelectric car cooler with cooling and heating function

- 8 litres capacity, ready for connection to 12 volts
- Fits 0.33-litre cans and 0.5-litre bottles

Ref. No. 9105302016

WAECO BordBar TB 15

4.08

Thermoelectric car cooler with cooling and heating function

- approx. 15 litres capacity, ready for connection to 12 volts
- Fits 1.5 and 2-litre bottles

Ref. No. 9105302023

Car coolers for everyone

What was formerly reserved for luxury automobiles is now affordable for everyone. TB 08 and TB 15 provide drivers and passengers with cool snacks and drinks. They will even keep hamburgers and chips warm. **Placed on the front passenger seat or the centre-piece of the rear seat, they are fastened with the safety belt.**

Stay put! Car coolers secured in place

**Crash
tested and
approved
for your
safety**

ISOFIX or safety belt

A firm hold for three popular classics

Your vehicle has an ISOFIX system? Then the best choice of car cooler is clearly the TE 21 ISO. It cools and heats, operates on 12/24/230 volts and was specially designed for the ISOFIX system. Just let it click in place – that's all! the TF 08 cools up to 20°C below the ambient temperature, the TF 14 achieves up to 25°C, and the TE 21 an amazing 30°C below ambient. Textile looks and a practical shoulder strap are the hallmarks of the two compact 12-volt car coolers. They are fastened with the safety belt or kept tight behind a seat.



A++
Energy class



WAECO BordBar TE 21 ISO

4.08

Thermoelectric car cooler for ISOFIX fastening

- 20 litres capacity, ready for connection to 12/24 and 230 volts
- TC special electronics
- Can be used for cooling and heating
- Vertical space for standing 2-litre bottles

Ref. No. 9103500528

**Cooling performance up to 30°C below ambient temperature
Fitted on the rear seat with ISOFIX system**



WAECO
BordBar TF 08



WAECO
BordBar TF 14

WAECO BordBar TF 08

4.08

Thermoelectric car cooler with roller shutter closure

- 8 litres capacity, ready for connection to 12 volts
- Vertical space for standing 1-litre bottles

Ref. No. 9105300001

WAECO BordBar TF 14

4.08

Thermoelectric car cooler with reinforced insulation

- 14 litres capacity, ready for connection to 12 volts
- Vertical space for standing 2-litre bottles

Ref. No. 9105302124

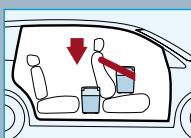

Perfect for a summer picnic



Mobile refrigeration



WAECO CoolFun S 28DC

Maritime chic, ample 25-litre capacity – grocery shopping is real fun with this cooler! Fitted with two Velcro straps on the sides, the CoolFun S 28 fastens to the shopping trolley for easy filling. To maintain the “cold chain” throughout the journey the thermoelectric bag is connected to the 12-volt car battery where it provides cooling up to 15°C below the ambient temperature.

WAECO CoolFun S 28DC

4.02

Shopping cool bag, 12 volts DC

- Capacity: approx. 25 litres
- Outside: hard-wearing polyester material
- Weight: 2.3 kg
- Dimensions (W x H x D): 370 x 410 x 230 mm

Ref. No. 9105302763

Tall enough to store large bottles upright
Three outer pockets for bits and pieces, adjustable carrier straps



Active cooling for tight budgets

Ample space for cool drinks or warm picnic food. The new CoolFun CX series “budget coolers” come in two sizes and accept three different energy sources: 12 volts, 12/24 volts or 12/230 volts. All models feature a practical cable compartment.

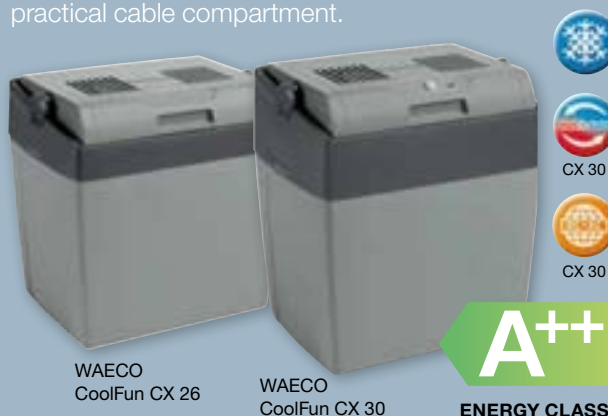

WAECO CoolFun CX 26 / CXT 26

4.02

Universal thermoelectric cooler

- Voltage/capacity: CX 26 – 12 volts, 25 litres
 CXT 26 – 12/24 volts, 25 litres
- Carrying handle also serves to support or lock the lid
- Cable compartment in the lid

Ref. No. 9103500871 (CX 26)

Ref. No. 9103500873 (CXT 26)



WAECO CoolFun CX 30

4.02

Universal thermoelectric cooler

- 12/230-volt connection as standard, 29 litres capacity
- Carrying handle also serves to support or lock the lid
- Cools and heats
- Cable compartment in the lid

Ref. No. 9103500872





High performance luxury cooling

WAECO TropiCool TC 35FL

4.01

Thermoelectric cooler with TC special electronics

- 33 litres capacity, ready for connection to 12/24 and 230 volts
- Vertical space for standing 2-litre bottles, optional fixing kit

Ref. No. 9105302110

Cooling performance up to 30°C below ambient temperature

WAECO TropiCool TC 21FL

4.01

Thermoelectric cooler with TC special electronics

- 20 litres capacity, ready for connection to 12/24 and 230 volts
- Vertical space for standing 2-litre bottles, optional fixing kit

Ref. No. 9105302085

Cooling performance up to 30°C below ambient temperature

WAECO TropiCool TC 14FL

4.01

Thermoelectric cooler with TC special electronics

- 14 litres capacity, ready for connection to 12/24 and 230 volts
- Room for 2-litre bottles, optional fixing kit

Ref. No. 9105302046

Cooling performance up to 30°C below ambient temperature

WAECO TropiCool TC 07

4.01

Thermoelectric cooler with shoulder strap

- 7 litres capacity, ready for connection to 12 and 230 volts
- Vertical space for standing 0.5-litre bottles

Ref. No. 9105302036

Cooling performance up to 25°C below ambient temperature

WAECO TropiCool TC 35FL

WAECO TropiCool TC 21FL

WAECO TropiCool TC 14FL

WAECO TropiCool TC 07



ENERGY CLASS
TropiCool TC 14FL
TropiCool TC 21FL
TropiCool TC 35FL

High-tech coolers in four sizes

Versatility, performance, perfect features and functions – these are the hallmarks of the WAECO TropiCool series. All boxes (except the TC 07) feature an intelligent power-save circuit, the temperature can be set as required and is displayed via LEDs. The compact devices provide cooling up to 30°C below the ambient temperature (TC 07 up to 25°C), and they can also be used for keeping food warm. TropiCool coolers operate on every DC power supply as well as on the mains.



Temperature range
+10°C to -18°C



Suitable for
solar operation



12/24 volts

Lightweight compressor cooling

Compact size with all the benefits

Powerful, suitable for deep-freezing, and amazingly compact for a compressor appliance: the two WAECO CoolFreeze coolers CDF 11 and CDF 16 are convenient to carry and easy to store in the car. 10.5 or 15 litres capacity for refrigeration and deep-freezing up to -18°C, regardless of the outside temperature.



WAECO
CoolFreeze CDF 11

WAECO
CoolFreeze CDF 16

NEW!

230-volt
connection with
low-priced mains
adapters

p. 60



WAECO CoolFreeze CDF 11

4.10

Portable compressor cooler for refrigeration and deep-freezing

- 10.5 litres capacity, ready for connection to 12/24 volts
- Temperature range: +10°C to -18°C
- Suitable for solar operation
- Extremely compact design, two integrated drinks holders
- Vertical space for standing 1-litre bottles
- Safe fastening in the vehicle with the seat belts

Ref. No. 9105100007

Adjustable shoulder strap for convenient transport
230-volt connection with low-priced mains adapter

WAECO CoolFreeze CDF 16

4.10

Portable compressor cooler for refrigeration and deep-freezing

- 15 litres capacity, ready for connection to 12/24 volts
- Temperature range: +10°C to -18°C
- Suitable for solar operation
- Space for two 1-litre bottles standing upright
- Electronic thermostat with digital temperature readout
- Detachable lid
- 3-stage battery guard, LED interior light

Ref. No. 9105303455

Electronic thermostat with digital temperature readout
230-volt connection with low-priced mains adapters



Compact compressor cooling

Slim, lightweight, powerful

These lightweight compressor coolers have capacities of 18 litres and 21.5 litres. Thanks to their optimised outside dimensions they will easily fit even into a crammed car – kept tight behind a front seat, or secured in the boot with a fixing kit (CDF 25).



230-volt connection with low-priced mains adapter
p. 60

WAECO CoolFreeze CDF 18

WAECO CoolFreeze CDF 25



Mobile refrigeration

WAECO CoolFreeze CDF 18

4.10

Portable compressor cooler for refrigeration and deep-freezing

- 18 litres capacity, ready for connection to 12/24 volts
- Temperature range: +10°C to -18°C
- Vertical space for standing 2-litre bottles
- Sturdy carrying handle

Ref. No. 9105100002

Lid can be folded up or detached
230-volt connection with low-priced mains adapter

WAECO CoolFreeze CDF 25

4.10

Portable compressor cooler for refrigeration and deep-freezing

- 21.5 litres capacity, ready for connection to 12/24 volts
- Temperature range: +10°C to -18°C
- Slim body – minimal space consumption
- Vertical space for standing 2-litre bottles

Ref. No. 9105100003

Removable wire basket, detachable lid
230-volt connection with low-priced mains adapter



CDF 18

Easy to operate, secure closing mechanism

Vertical insertion of the folding grid: space for standing 2-litre bottles



CDF 25

Safe locking mechanism: easy to open and close with one hand

Left: continuously variable electronic thermostat; right: two-stage battery monitor

CoolFreeze CFX – the most powerful compressor coolers ever seen



WAECO
CoolFreeze CFX 35

WAECO
CoolFreeze CFX 40

A++
ENERGY CLASS

High-tech compressor coolers for refrigeration and deep-freezing

A++ energy ratings and **deep-freeze temperatures down to -22°C** are exceptional features in the world of mobile cooling! The WAECO CoolFreeze CFX series from cooling specialist Dometic WAECO marks another milestone. With a purpose-built high-performance compressor and an extra-thick insulation layer, the energy consumption was reduced to a level up to 35% lower than that for the predecessor models. Heavy-duty details such as reinforced corners, stainless steel hinges and a robust lid coating qualify the CFX boxes for extreme demands. At the same time they are amazingly light and easy to transport.

- 12/24 volts DC and 100 – 240 volts AC
- Extremely energy-saving and quiet-running
- For car, van and home use

WAECO CoolFreeze CFX 35

4.30

Portable compressor cooler for refrigeration and deep-freezing

- Capacity: approx. 32 litres (incl. 4.5 litres for fresh food)
- Weight: 17.5 kg
- Current consumption: 0.32 Ah/h at $+20^{\circ}\text{C}$ ambient temperature
0.60 Ah/h at $+32^{\circ}\text{C}$ ambient temperature
both at $+5^{\circ}\text{C}$ interior temperature

Ref. No. 9105304047

Intelligent, automatic turbo cooler

WAECO CoolFreeze CFX 40

4.30

Portable compressor cooler for refrigeration and deep-freezing

- Capacity: approx. 38 litres (incl. 7.0 litres for fresh food)
- Weight: 18.5 kg
- Current consumption: 0.36 Ah/h at $+20^{\circ}\text{C}$ ambient temperature
0.64 Ah/h at $+32^{\circ}\text{C}$ ambient temperature
both at $+5^{\circ}\text{C}$ interior temperature

Ref. No. 9105304048

Freely adjustable cooling temperature



Mobile refrigeration

WAECO CoolFreeze CFX 50

4.30

Portable compressor cooler for refrigeration and deep-freezing

- Capacity: approx. 46 litres (incl. 8.5 litres for fresh food)
- Weight: 20.4 kg
- Current consumption: 0.38 Ah/h at +20°C ambient temperature
0.68 Ah/h at +32°C ambient temperature
both at +5°C interior temperature

Ref. No. 9105304049

Digital temperature readout, soft start and turbo cooler

WAECO CoolFreeze CFX 65

4.30

Portable compressor cooler for refrigeration and deep-freezing

- Capacity: approx. 60 litres (incl. 13.6 litres for fresh food)
- Weight: 22.3 kg
- Current consumption: 0.42 Ah/h at +20°C ambient temperature
0.76 Ah/h at +32°C ambient temperature
both at +5°C interior temperature

Ref. No. 9105304050

WAECO CoolFreeze CFX 65DZ

4.30



For simultaneous cooling and freezing

- Capacity approx. 53 litres (incl. 17-litre freezer compartment)
- Weight 23.2 kg
- Current consumption: 0.42 Ah/h at +20°C ambient temperature
0.76 Ah/h at +32°C ambient temperature
both at +5°C interior temperature

Ref. No. 9105304051

Dual compartment – for simultaneous cooling and freezing

Professional size coolers:
Deep-freezing jumbo size: CF 80 and CF 110 with 79 or 105 litres capacity. All technical data on page 61



WAECO CoolFreeze CFX 50

WAECO CoolFreeze CFX 65



ENERGY CLASS



WAECO CoolFreeze CFX 65DZ

CoolFreeze CFX-WD wireless display

4.30



For all CFX compressor coolers

- Remote display showing the cooling temperature, power source, battery protection and alarm settings
- Visual and acoustic alarm
- Powered by AAA-batteries or 12/24 V cigarette lighter

Ref. No. 9105304065

The wireless display allows data such as the current temperature, power supply or alarm, to be shown up to 15 m away from the CFX cooler.





Here we go – full of energy!

Electronic accessories from the expert



Intelligent energy management

From sine wave inverters to battery care products

Have a flying start and enjoy your journey with home amenities. Electronic accessories from WAECO make sure you will always have plenty of energy on board. Well engineered products keep the vehicle battery in good working order to provide reliable power supply for all the devices you want to use on the go.

Our comprehensive product range is based on decades of experience in the automotive industry.



e. g. the inverter
PerfectPower PP 152

p. 45

**Perfect
power
supply**

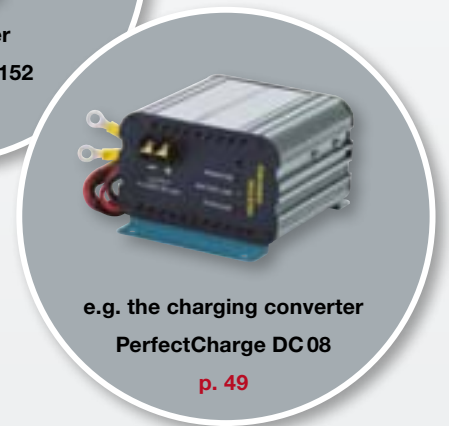

e.g. the charging converter
PerfectCharge DC 08

p. 49



It charges them all!

Universal charger for laptops and more

When your laptop battery goes flat during the journey, you can charge it up from the vehicle battery. WAECO PocketPower LC is a trustworthy charger for notebooks of all leading brands. It also, and simultaneously, charges other mobile terminals like mobile phones, smart phones, DVD players, GPS, etc. The compact universal charger recognises the connected device and

adjusts the charging voltage accordingly. This finally puts an end to the risk of damaging a device by using the wrong charging voltage.



Lockable DC plug



WAECO PocketPower LC



3.29

Universal charger for laptops and many other mobile terminals

- Suitable for over 400 different laptop models (13 adapters in the delivery kit)
- USB port and micro-USB cable for simultaneous charging of mobile phones
- Automatically recognises the voltage and adjusts itself accordingly
- Input voltage range 12 – 24 volts

Ref. No. 9102500022

LED data display
Patented hook system for fastening the charger in the vehicle

Designed for universal use

Simultaneous charging of laptops and other digital terminals.
100% compatible with DVD players, mobile phones, GPS, PSP, MP3

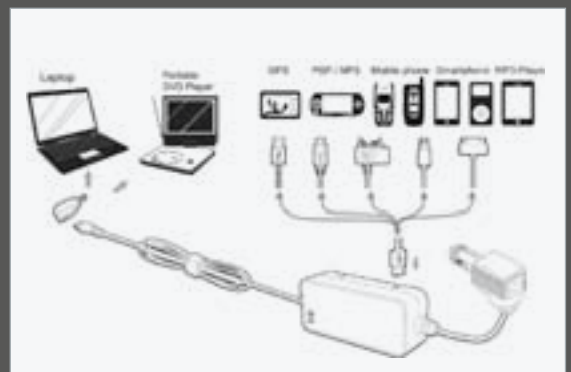



Pocket size inverter



Modified sine wave
voltage

Light weight, compact and easily installed

Rechargeable batteries of small mobile consumers as electric shaver, camera etc. tend to run low in the most inappropriate moment on the move.

The WAECO PocketPower SI 102 smart inverter doesn't let it get to that point. It takes power from the 12-volts car battery to charge the devices and keep them up and running. The handy unit generates a sine-like 230-volts alternating voltage, which is fine for many applications.



With euro
socket

WAECO PocketPower SI 102



3.29

Smart inverter, 100 watts, for mobile use

- For operation of low-power devices
- Low-voltage and over-voltage cut-off
- Overload and short-circuit protection
- With USB charging port

100 watts, 12 volts // Ref. No. 9105303816

**With mounting bracket and euro socket
LED status indication**

Modified sine wave voltage

The voltage produces a stepped curve simulating a sine wave.
The result: an output voltage of stable amplitude and frequency

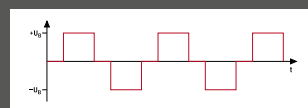

Pure sine wave voltage

The voltage is accurately controlled by a microprocessor.
The result: a clean sine wave voltage, like that from a home power socket

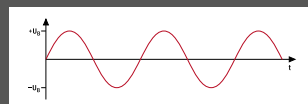



230 volts for many frequently used devices

**Models from
150 – 2000
watts**



Inverters with modified sine wave voltage

The inexpensive WAECO PerfectPower inverters generate a modified output voltage – which is fully adequate for all devices with a wide input voltage range (power drills, hair-dryers, vacuum cleaners). The two high-performance inverter models (1000/2000 watts) offer the extra benefits of a mains priority circuit and a remote control output.



Mobile electronics

<p>WAECO PerfectPower inverters   turn 12-volts battery voltage into a sine-wave-like 230-volts alternating voltage.</p>	
<p>WAECO PerfectPower PP 152</p> <p>→ Continuous output: 150 watts, peak output: 350 watts → Cigarette lighter plug, individually adjustable clip-on mounts</p> <p>Ref. No. 9105303791 // UK: 9105303792</p>	<p>3.18</p>
<p>WAECO PerfectPower PP 402</p> <p>→ Continuous output: 350 watts, peak output: 700 watts → Individually adjustable clip-on mounts</p> <p>Ref. No. 9105303796 // UK: 9105303797</p>	<p>3.18</p>
<p>WAECO PerfectPower PP 602</p> <p>→ Continuous output: 550 watts, peak output: 1100 watts → Individually adjustable clip-on mounts</p> <p>Ref. No. 9105303801 // UK: 9105303802</p>	<p>3.18</p>
	
<p>WAECO PerfectPower PP 1002</p> <p>→ Continuous output: 1000 watts, peak output: 2000 watts → Mains priority circuit, outputs for remote control and an external switch</p> <p>Ref. No. 9102600002 // UK: 9102600003</p>	<p>3.18</p>
<p>WAECO PerfectPower PP 2002</p> <p>→ Continuous output: 2000 watts, peak output: 4000 watts → Mains priority circuit, outputs for remote control and an external switch</p> <p>Ref. No. 9102600027 // UK: 9102600005</p>	<p>3.18</p>

Light weight, compact size, high peak output rating



Pure sine wave voltage



MSI 1812



MSI 1312



MSI 212

WAECO SinePower inverters turn 12-volt battery voltage into a pure 230-volt alternating voltage.



WAECO SinePower MSI 212/MSI 412 3.30

- Continuous output: 150/350 watts, peak output: 300/700 watts
- USB interface, super-flat design
- Ideal for applications in cars or vans

MSI 212 // Ref. No. 9102600124

MSI 412 // Ref. No. 9102600126

WAECO SinePower MSI 912/MSI 1312 3.30

- Continuous output: 900/1300 watts
- Peak output: 1600/2400 watts
- Ideal for mobile operation of power drills, sanders and other tools
- Designed for permanent installation in the boot or cargo area

MSI 912, 12 V // Ref. No. 9102600111 // UK: 9102600033

MSI 1312, 12 V // Ref. No. 9102600113 // UK: 9102600035

WAECO SinePower MSI 1812/MSI 1812T 3.30

- Continuous output: 1800/1800 watts
- Peak output: 3200/3200 watts
- MSI 1812 T with integrated mains priority circuit
- Ideal for simultaneous operation of several devices, e.g. power tools
- Designed for permanent installation in the boot or cargo area

MSI 1812, 12 V // Ref. No. 9102600115 // UK: 9102600037

MSI 1812T, 12 V // Ref. No. 9102600117 // UK: 9102600039

The WAECO inverters for pure sine wave voltage

AC power just like home: WAECO SinePower sine wave inverters ensure trouble-free mobile operation of all 230-volts devices, even sensitive ones (e.g. computers, coffee makers, electric toothbrushes).

The lightweight and installation-friendly inverters feature excellent output ratings, so they have ample power to serve devices with high start-up currents.



Small and light, fitted in a trice

Luxury-class charging technology: The IU0U chargers from WAECO

Suitable for all battery types, 6-step charging characteristics: the WAECO PerfectCharge automatic battery chargers are gentle on the batteries and extremely fast to charge. Due to their amazingly light weight and compact size, they are a treat to install, even in confined spaces.



MCA 1235

MCA 1225

MCA 1215

Mobile electronics

WAECO PerfectCharge MCA 1215

3.16

- Charging current: 15 A, charger outputs: 1 + 1
- Weight: 1.6 kg
- Sleep-mode function for quiet charging with the fan turned off

12 volts // Ref. No. 9102500027 // UK: 9102500046

WAECO PerfectCharge MCA 1225

3.16

- Charging current: 25 A, charger outputs: 2 + 1
- Weight: 1.7 kg
- Sleep-mode function for quiet charging with the fan turned off

12 volts // Ref. No. 9102500028 // UK: 9102500047

WAECO PerfectCharge MCA 1235

3.16

- Charging current: 35 A, charger outputs: 2 + 1
- Weight: 1.9 kg
- Sleep-mode function for quiet charging with the fan turned off

12 volts // Ref. No. 9102500029 // UK: 9102500048



Two bus interfaces as standard



DIP switches



Digital interface



The smart battery charger

Easy operation – universal use

DEFA SmartCharge makes battery charging simpler and safer than ever before. The charger recognises automatically which type of battery is connected. It adjusts the charging process to the charge state, the battery capacity and the ambient temperature.

The handy device is the perfect shape and can be kept tidy with its smart cable management system. Suitable for all common lead acid batteries with a capacity up to 120 Ah, it offers virtually unlimited uses. Cars, motorhomes, motorbikes, scooters – it will even recharge the battery of a lawnmower.

DEFA[®] PowerSystems



- Error indicator
- Charge state indicator
- Gel/AGM batteries
- ON/OFF switch

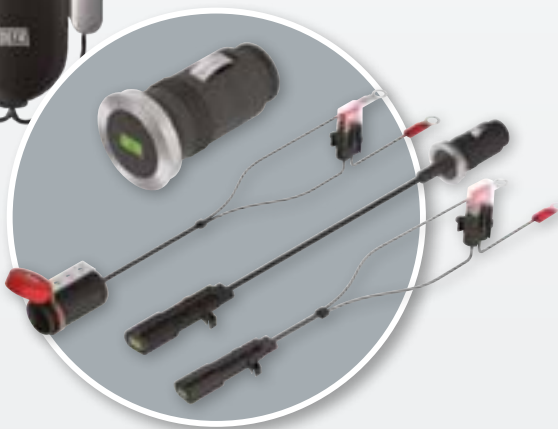

DEFA SmartCharge



3.45

Universal battery charger

- For wet, gel and AGM batteries from 4 to 120 Ah
- Automatically adjusts the charging characteristics to the battery type
- Status indication for the charging process
- One-button operation

Ref. No. 701515

Power supply function (when the vehicle battery is replaced)

Charge state indicator and diverse charger cables as accessories

Charging on the road

A full charge while driving

WAECO PerfectCharge DC 08 / DC 20 / DC 40



IU charging converters with electrically isolated input and output voltage

- Completely recharge the battery during the drive
- Compensate voltage drops and peaks
- Provide a stable voltage for sensitive electrical appliances
- Several converters can be used in parallel

WAECO PerfectCharge DC 08 3.16

- Nominal input voltage: 12 volts DC
- Input voltage range: 8 – 16 volts DC
- Output current: 8 A
- Electronically controlled output voltage of 14.2 volts DC \pm 0.1 volts

Ref. No. 9102500055

WAECO PerfectCharge DC 20 3.16

- Nominal input voltage: 12 volts DC
- Input voltage range: 8 – 16 volts DC
- Output current: 20 A
- Electronically controlled output voltage of 14.2 volts DC \pm 0.1 volts

Ref. No. 9102500045

WAECO PerfectCharge DC 40 3.16

- Nominal input voltage: 12 volts DC
- Input voltage range: 8 – 16 volts DC
- Output current: 40 A
- Electronically controlled output voltage of 14.2 volts DC \pm 0.1 volts

Ref. No. 9102500056



DC 40

DC 20

DC 08

IU charging converters give leisure batteries a full charge

The electric generator often doesn't manage to completely recharge the leisure battery during the journey. This drawback is easily overcome with a WAECO PerfectCharge charging converter. Integrated in the wiring it raises the charging voltage to 14.2 volts to ensure optimal charging during the drive. Moreover, it stabilises the voltage supply for sensitive 12-volt appliances (e.g. navigation systems, LCD monitors), which require a constant and stable voltage.

Charging, conditioning, care for the battery

**With
fixing
attachments**



Battery charger and conditioner

A super-compact battery charger with IUOU charging characteristics, ideal for permanent installation. WAECO PerfectBattery BC 400 gives starter and leisure batteries up to 100 Ah a full charge. It can also be used for boost charging of batteries with larger capacity.

WAECO PerfectBattery BC 400



3.28

Battery charger and conditioner for 12-volt batteries

- IUOU charging characteristics
- For battery capacities up to 100 Ah
- 3 different connection cables
- 4 fixing attachments for permanent installation

Ref. No. 9103555808

Compact charger for permanent installation





Battery conditioner and refresher

WAECO PerfectBattery BC 100 maintains 12-volt lead batteries by gently simulating driving. As a result, the full capacity can be maintained even after longer periods of standstill. The battery conditioner can also be used as a charger or back-up power supply.

WAECO PerfectBattery BR 12 reduces sulphate build-up, the cause for premature battery ageing and failure. It treats the battery to a regular training programme to multiply its service life. Even apparently useless batteries can be reactivated.



WAECO PerfectBattery BC 100



Battery conditioner for 12-volt lead batteries

Three functions in one unit: conditioning, charging, back-up

- Conditions batteries with a capacity from 10 Ah to 150 Ah
- Charges batteries with a capacity from 10 to 30 Ah
- Can also be used as back-up power supply

Ref. No. 910250044

Ideal for bridging longer periods of inactivity

WAECO PerfectBattery BR 12



Battery refresher for 12-volt lead batteries

Extends the service life of gel, AGM and wet batteries

- Simply connected to the battery's minus and plus poles
- Multiplies the battery's service life by reducing sulphate build-up
- Reactivates apparently defective batteries

Ref. No. 9103556045

Can be used on batteries up to 300 Ah



**Drive your car and
feel at home**

Coffee, tea and a clean car

Kitchen and household devices for mobile use

Let the others rush, while you focus on your own well-being! Have a break now and then, take a few minutes rest, and you'll get to your destination much more refreshed. Mobile coffee makers and the electric kettle from WAECO provide you with your favourite hot drink. We also recommend the compact battery vacuum cleaner as after all, you can relax even better in a clean car.



PerfectCoffee MC 01
1-cup coffee maker



PerfectKitchen MCK 750
Electric kettle



WAECO PowerVac PV 100
Wet-and-dry vacuum cleaner



For a warm feeling inside

**Coffee, tea or soup –
in no time at all**

Place coffee into the filter, pour water into the tank, press the button – five minutes later your pick-me-up drink is ready. The 1-cup coffee maker with the beautiful ceramic mug is ideal

for trips on your own. For a cup of tea, cappuccino or instant soup, use the electric kettle.



WAECO PerfectCoffee MC 01



3.13

1-cup coffee maker, 12 or 24 volts

- Fresh coffee after 5 minutes brewing time
- Fixing kit for desk mounting
- For cars, trucks, motorhomes or boats
- Designed for mobile use

12 volts // Ref. No. 9103533009

24 volts // Ref. No. 9103533010

WAECO PerfectKitchen MCK 750



3.14

Electric kettle for 12 and 24 volts

- 750 ml capacity
- Auto shut-off upon boiling or when kettle is empty
- Robust relay technology
- Wall or desk mounting

12 volts // Ref. No. 9103533003

24 volts // Ref. No. 9103533004

Safe and stylish design

Quenching your thirst with a coffee

The super-slim 8-cup brewer

Measuring only 10 cm in depth the stylish WAECO PerfectCoffee MC 08 can be easily accommodated in the vehicle. It can be desk or wall mounted as it prepares up to eight cups of coffee in just a few minutes, then turns off automatically. The coffee stays hot and fresh for a long time in the elegant thermal flask.

Space-saving design



WAECO PerfectCoffee MC 08



3.13

Coffee maker de Luxe, 8 cups, 12 or 24 volts

- Slim, space-saving design
- Automatic cut-off after brewing
- Removable water tank
- Robust relay technology

12 volts // Ref. No. 9103533005

24 volts // Ref. No. 9103533002

Supplied with thermal flask and fixing kit



WAECO PerfectCoffee MC 05



3.13

Coffee maker 5 cups, 12 or 24 volts

- Transparent water tank with cup scale
- Glass pot with integrated transport securing device
- Hotplate with thermostat
- Robust relay technology

12 volts // Ref. No. 9103533007

24 volts // Ref. No. 9103533001

Well-proven compact coffee maker for mobile use

Inexpensive compact model for 5 cups

The WAECO PerfectCoffee MC 05 has been part of our range for a long time and has won many loyal fans. It brews up to 5 cups of coffee and features a glass pot, a transparent water tank and a hotplate. A fixing kit for desk or wall mounting gives it a firm hold in the vehicle.



Eliminate that dirt!



Wet-and-dry vacuum cleaner

The handy WAECO PowerVac PV 100 comes with integrated battery – no need for an external power supply. Up to 18 minutes of intensive cleaning is possible. Then recharge the vacuum cleaner from the mains or 12-volt battery. Amazingly strong, the PowerVac gets rid of the most ground-in dirt and even liquids. It is a practical, universal gadget that requires little room for storage.

**Cordless
convenience**

WAECO PowerVac PV 100



3.31

Wet/dry vacuum cleaner with 12-volt battery

- Maximum mobility with 12-volt battery
- Can be recharged from 12 and 230 volts
- Cleaning power: 400 mm water column
- Easy-to-clean dust container and fabric filter
- Diverse (brush) attachments for narrow gaps, doormats, rugs and upholstery

Ref. No. 9103500212

Ideal for all kinds of vehicles, for home and workshop use
Compact design, can be easily stored away



No more ice-scraping

Modular vehicle preheating systems

More safety through clear vision!

An easy start in winter too

Modular vehicle preheating systems

Forget about the winter morning routine of scraping the ice off, getting into a deep-frozen seat and struggling with the ignition. DEFA has made sure that the windows are clear, the car is warm and comfortable inside, the engine is ready to start. The well-proven vehicle preheating systems from Scandinavia are far less expensive than an independent vehicle heater. You can opt for one of our complete kits, or

create your personal “warm-up” package by combining the components of your choice.

The new Termini™ II 1400 heater, for instance. It warms up your car extremely quickly and efficiently. This reduces the connection time and cuts energy costs as a result. Barely larger than a slim paperback, it can be fitted neatly and inconspicuously in the vehicle.

Termini™ II 1400

3.11

Interior heater

- Output at -25°C: 0/1400 watts
- Width/height/depth: 138/28/182 mm
- Weight incl. bracket: 615 g
- IP rate: 20
- Operating temperature: -40°C to +80°C
- Connection cable: 0.60 m

Ref. No. A430055 (MiniPlug)

Ref. No. A430056 (shaped plug)

The slimmest and most efficient interior heater in the market

NEW





The three most common DEFA kits – designed as a modular system 3.11



1 DEFA SafeStart – Engine heater

- ✓ Up to 35% fuel savings on shorter drives
- ✓ Less engine wear
- ✓ Up to 33% reduction of harmful waste gas emission
- ✓ Available for specific vehicles



3 WarmUp Kit – Complete car heating system

- ✓ Up to 35% fuel savings on shorter drives
- ✓ Less engine wear
- ✓ Up to 33% reduction of harmful waste gas emission
- ✓ Warm interior, ice-free windows
- ✓ Fully charged battery at all times
- ✓ Longer battery life
- ✓ Summer starting whenever you wish



2 ComfortKit – Engine heater and interior heater

- ✓ Up to 35% fuel savings on shorter drives
- ✓ Less engine wear
- ✓ Up to 33% reduction of harmful waste gas emission
- ✓ Warm interior, ice-free windows

+ DEFA SmartStart™ – Radio remote control



SmartStart™
2-way radio remote control on a key ring for maximum convenience.



+ DEFA Futura – Control unit



Futura Automatik
Easy-to-use timer with digital display and automatic mode to be programmed the day before.

4.08 // WAECO BordBar

Thermoelectric coolers

						
Ref. No.	AS 25 9105302816	TB 08 9105302016	TB 15 9105302023	TF 08 9105300001	TF 14 9105302124	TE 21 ISO 9103500528
Storage volume (l, approx.)	20	8	15	8	14	20
Connections	12 V DC/ 230 V AC	12 V DC	12 V DC	12 V DC	12 V DC	12/24 V DC 230 V AC
Consumption at 12 V DC (watts) at 24 V DC (watts) at 230 V AC (watts)	36 — 40	32 — —	40 — —	36 — —	36 — —	36 — —
Energy class	A++	—	—	—	—	A++
Temperature range Cooling below ambient temperature (°C, approx.) Heating (°C, approx.)	max. 18 —	max. 20 +65	max. 20 +65	max. 20 —	max. 25 —	max. 30 +50 to +65
Insulation PU foam all around	●	ISOFOAM	●	●	●	●
System Thermoelectric (Peltier system)	●	●	●	●	●	●
Material		PP	ABS	Frame components in plastic, textile cover in high-quality Oxford nylon	Exterior in high-quality Oxford nylon, sides in hard-wearing, rubber-coated nylon	Cabinet of sturdy injection-moulded parts
Colour		Anthracite/ grey	Dark grey/ pale grey	Black/ pale grey	Silver-grey/ black	Dark grey/ pale grey
Weight (kg, approx.)	4.3	3.2	5.2	3.5	4.6	6.0
Test marks TÜV/GS, e-certified (Automotive EMC Directive)	●	●	●	●	●	●
Optional extra						
Universal fixing kit UFK-T	—	—	—	—	—	—
Mains adapter EPS 817 230 V AC > 12 V DC	—	9102600030	9102600030	9102600030	9102600030	—
Voltage monitor	—	9105303854	9105303854	9105303854	9105303854	—

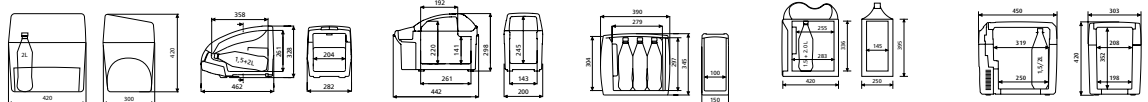

Electronic accessories for coolers



CoolPower EPS 817

Mains adapter for connecting
thermoelectric 12-volt cooling appliances

Ref. No.	9102600030	
Input voltage	110 – 240 V AC	Dimensions (W x H x D)
Output voltage	13 V DC	115 x 65 x 170 mm
Continuous load	6 A	Weight (kg)
		0.6
		Test mark
		GS

4.01 // WAECO TropiCool



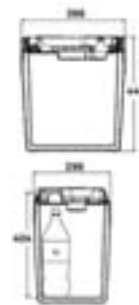
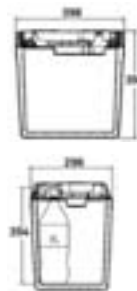
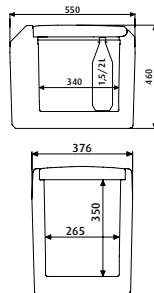
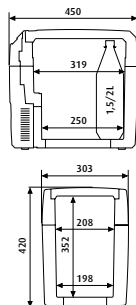
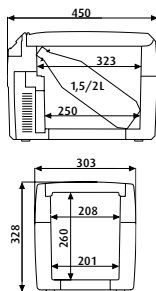
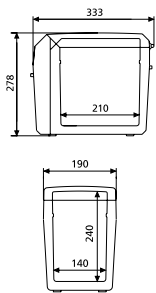

4.02 // WAECO CoolFun

4.01 // WAECO TropiCool				4.02 // WAECO CoolFun		
TC 07 9105302036	TC 14FL 9105302046	TC 21FL 9105302085	TC 35FL 9105302110	CX 26/CXT 26 9103500871 9103500873	CX 30 9103500872	S 28DC 9105302763
7 12 V DC/ 230 V AC	14 12/24 V DC/ 230 V AC	20 12/24 V DC/ 230 V AC	33 12/24 V DC/ 230 V AC	25 CX 26 = 12 V DC CXT 26 = 12/24 V DC	29 12 V DC/ 230 V AC	25 12 V DC
36 — 40 —	46 50 64 A++	46 50 64 A++	46 50 64 A++	47 55 — —	47 — 55 A++	35 — — —
max. 25	max. 30	max. 30	max. 30	max. 18	max. 18	max. 15
+65	+50 to +65	+50 to +65	+50 to +65	—	+65	—
•	•	•	•	•	•	Lightweight full insulation
•	•	•	•	•	•	•
Injection moulded parts	Injection moulded parts	Injection moulded parts	Injection moulded parts	Polypropylene	Polypropylene	Plastic: PP Bag: Textile
Dark grey/ pale grey	Dark grey/ pale grey	Dark grey/ pale grey	Dark grey/ pale grey	Dark grey/ pale grey	Dark grey/ pale grey	Beige/ dark blue
2.8	5.0	6.0	10.0	CX 26 3.7/CXT 26 4.0	4.3	2.3
•	•	•	•	•	•	•
—	9105303709	9105303709	9105303709	—	—	—
—	—	—	—	9102600030	—	9102600030



4.10 // WAECO CoolFreeze GDF





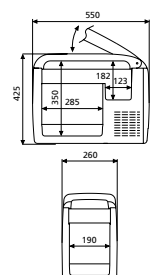
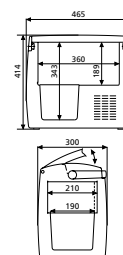
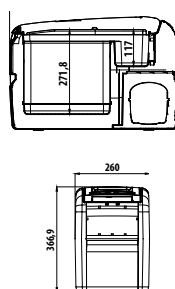
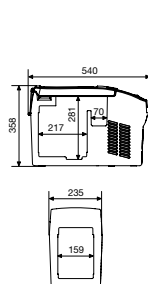

Compressor coolers

				
	CDF 11	CDF 16	CDF 18	CDF 25
Ref. No.	9105100007	9105303455	9105100002	9105100003
Storage volume (l, approx.) incl. for fresh food (l)	10,5 –	15 –	18 –	21.5 4
Connections	12/24 V DC	12/24 V DC	12/24 V DC	12/24 V DC
Temperature range	+10°C to –18°C	+10°C to –18°C	+10°C to –18°C	+10°C to –18°C
Power input (watts, approx.)	35	35	35	35
Current consumption (Ah/h) at +20°C +32°C ambient temperature, both at +5°C interior temperature	0.29 0.61	0.21 0.44	0.38 0.64	0.44 0.67
Energy class	–	–	–	–
Insulation PU foam all around	•	•	•	•
System Fully hermetic compressor with integrated control electronics	•	•	•	•
Electronic thermostat	•	•	•	•
Low voltage protection / Electronic fuse	•	•	•	•
Automatic reverse pole protection	•	•	•	•
Material	Cabinet: PP Lid: PE	Cabinet: PP Lid: PE	Cabinet: PP Lid: PE	Cabinet: PP Lid: PE
Colour	Pale grey / dark grey	Pale grey / dark grey	Pale grey / dark grey	Pale grey / dark grey
Weight (kg, approx.)	10.5	11.5	11.5	12.5
Test marks TÜV/GS, e-certified (Automotive EMC Directive)	e-certified (Automotive EMC Directive)	•	•	•
Scope of delivery Removable wire basket	–	–	–	•
Detachable carrying handles	–	–	–	–
Optional extras				
Mains adapter 230 V > 24 V	9102600031	9102600031	9102600031	9102600031
Mains adapter 110 V – 240 V > 24 V	9103555825	9103555825	9103555825	9103555825
Universal fixing kit	–	9105303708	–	9105303708
NEW! Wireless Display	–	–	–	–



4.30 // WAECO CoolFreeze CFX

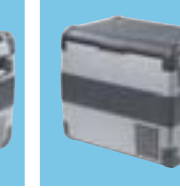
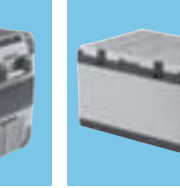

4.10 // WAECO CoolFreeze CF

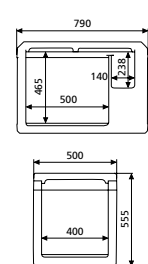
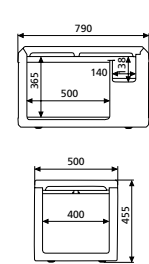
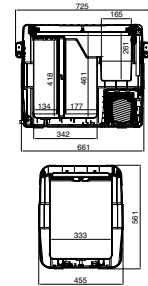
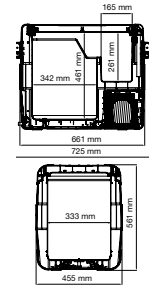
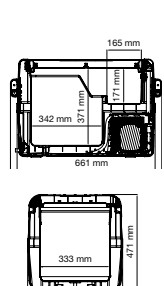
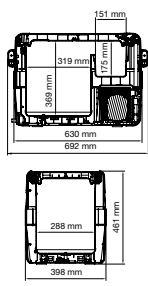
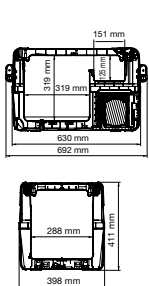
						
CFX 35	CFX 40	CFX 50	CFX 65	CFX 65DZ	CF 80	CF 110
9105304047	9105304048	9105304049	9105304050	9105304051	9105303248	9105303102
32 4.5	38 7	46 8.5	60 13	53 13 + 17 (freezer)	79 7	105 13
12/24 V DC 100–240 V AC	12/24 V DC 100–240 V AC	12/24 V DC 100–240 V AC	12/24 V DC 100–240 V AC	12/24 V DC 100–240 V AC	12/24 V DC 100–240 V AC	12/24 V DC 100–240 V AC
+10°C to –22°C	+10°C to –22°C	+10°C to –22°C	+10°C to –22°C	+10°C to –22°C	+10°C to –18°C	+10°C to –18°C
43	48	52	58	50	65	65
0.32 0.60	0.36 0.64	0.38 0.68	0.42 0.76	0.42 0.76	0.65 1.19	0.76 1.35
A++	A++	A++	A++	A+	A+	A+
•	•	•	•	•	•	•
•	•	•	•	•	•	•
•	•	•	•	•	•	•
•	•	•	•	•	•	•
•	•	•	•	•	•	•
Cabinet: PP + ABS Lid: PE	Cabinet: PP + ABS Lid: PE	Cabinet: PP + ABS Lid: PE	Cabinet: PP + ABS Lid: PE	Cabinet: PP + ABS Lid: PE	Cabinet: coated sheet steel Top and base: PP Lid: PE	
Pale grey/ dark grey	Pale grey/ dark grey	Pale grey/ dark grey	Pale grey/ dark grey	Pale grey/ dark grey	Pale grey/ dark grey	Pale grey/ dark grey
17.5	18.5	20.4	22.3	22.3	31	33
•	•	•	•	•	•	•
•	•	•	•	•	•	•
•	•	•	•	•	•	•
—	—	—	—	—	—	—
—	—	—	—	—	—	—
—	—	—	—	—	—	—
9105304065	9105304065	9105304065	9105304065	9105304065	—	—





Chargers

3.16 // WAECO PerfectCharge





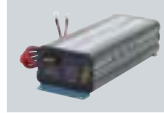

			
	MCA 1215	MCA 1225	MCA 1235
Ref. No.	9102500027	9102500028	9102500029
Ref. No. UK	9102500046	9102500047	9102500048
Maximum charging current (A)	15	25	35
Battery outputs	1 + 1	2 + 1	2 + 1
Recommended battery capacity (Ah)	40 – 170 (Ah)	75 – 300 (Ah)	100 – 400 (Ah)
Energy efficiency up to	92 %	92 %	92 %
Sleep mode	Via remote control or a DIP switch on the device		
Input voltage	90 V – 260 V	90 V – 260 V	90 V – 260 V
Output voltage	–	–	–
Battery types	Lead-acid batteries (liquid, gel, AGM)		
Frequency	50 – 60 Hz	50 – 60 Hz	50 – 60 Hz
Operating temperature	–20°C to +50°C	–20°C to +50°C	–20°C to +50°C
Dimensions (W x H x D, mm)	179 x 63 x 238	179 x 63 x 238	179 x 63 x 274
Weight (kg)	1.6	1.7	1.9
Test mark	–	–	–
+ Optional extras			
Temperature sensor MCA-TS1	9102500036	9102500036	9102500036
Remote control MCA-RC1	9102500037	9102500037	9102500037

3.16 // WAECO PerfectCharge Charging converters

			
	DC 08	DC 20	DC 40
Ref. No.	9102500055	9102500045	9102500056
Maximum charging current (A)	8	20	40
Battery outputs	–	–	–
Recommended battery capacity (Ah)	–	–	–
Energy efficiency up to	87 %	87 %	87 %
Input voltage	12 V DC (8 – 16 V)	12 V DC (8 – 16 V)	12 V DC (8 – 16 V)
Output voltage	14.2 V DC ±0.1 V	14.2 V DC ±0.1 V	14.2 V DC ±0.1 V
Battery types	–	–	–
Frequency	–	–	–
Operating temperature	–	–	–
Dimensions (W x H x D, mm)	115 x 70 x 100	115 x 70 x 160	115 x 70 x 270
Weight (kg)	0.75	1.2	2.1
Test mark	e-certified (Automotive EMC Directive)		
+ Optional extras			
Temperature sensor MCA-TS1	–	–	–
Remote control MCA-RC1	–	–	–

Sine wave inverters

3.30 // WAECO SinePower

						
	MSI 212	MSI 412	MSI 912	MSI 1312	MSI 1812	MSI 1812T
Ref. No.	9102600124	9102600126	9102600111	9102600113	9102600115	9102600117
Ref. No. UK			9102600033	9102600035	9102600037	9102600039
Nominal input voltage	12 V DC (11 – 15 V)	12 V DC (11 – 15 V)	12 V DC (10.5 – 16 V)	12 V DC (10.5 – 16 V)	12 V DC (10.5 – 16 V)	12 V DC (10.5 – 16 V)
Output voltage/curve pure sine wave 	230 V AC	230 V AC	230 V AC	230 V AC	230 V AC	230 V AC
Output voltage USB	5 V DC, 2 A	5 V DC, 2 A	–	–	–	–
Output frequency	50 Hz	50 Hz	50 Hz	50 Hz	50 Hz	50 Hz
No-load current input	0,6 A	0,6 A	1,8 A	2,1 A	2,1 A	2,1 A
Standby current consumption	–	–	0,5 A	0,5 A	0,5 A	0,5 A
Continuous power	150 W	350 W	900 W	1300 W	1800 W	1800 W
Peak power	300 W	700 W	1600 W	2400 W	3200 W	3200 W
Integrated priority circuit	–	–	–	–	–	•
Operating temperature	–20°C to +40°C	–20°C to +40°C	–20°C to +40°C	–20°C to +40°C	–20°C to +40°C	–20°C to +40°C
Energy efficiency up to	90 %	90 %	92 %	92 %	92 %	92 %
Dimensions (W x H x D, mm)	124 x 49 x 199	124 x 49 x 199	197.5 x 94.3 x 291	197.5 x 94.3 x 324.6	197.5 x 94.3 x 376	197.5 x 94.3 x 406
Weight (ca. kg)	0.82	0.82	3	4	5	6.5
Test mark	•	•	•	•	•	•
+ Optional extras						
Comfort remote control MCR-7	–	–	9102600001	9102600001	9102600001	9102600001
Standard remote control MCR-9	–	–	9102600026	9102600026	9102600026	9102600026
Mains priority circuit VS-230	–	–	9103556043	9103556043	–	–

3.18 // WAECO PerfectPower

Inverters

					
	PP 152	PP 402	PP 602	PP 1002	PP 2002
Ref. No.	9105303791	9105303796	9105303801	9102600002	9102600027
Ref. No. UK	9105303792	9105303797	9105303802	9102600003	9102600005
Input voltage	12 V DC (11 – 15 V)			12 V DC (11 – 15 V)	
Output voltage/curve	230 V AC / modified sine wave $\overline{\square}$			230 V AC / modified sine wave $\overline{\square}$	
Output frequency	50 Hz	50 Hz	50 Hz	50 Hz	50 Hz
No-load input current	0.25 A	0.25 A	0.25 A	< 0.8 A	< 1.5 A
Continuous power	150 W	350 W	550 W	1000 W	2000 W
Peak power	350 W	700 W	1100 W	2000 W	4000 W
Cooling	Ventilator	Ventilator	Ventilator	Ventilator	Ventilator
Energy efficiency	up to 90 %	up to 90 %	up to 90 %	up to 85 %	up to 85 %
Mains priority circuit	–	–	–	•	•
Dimensions (W x H x D)	129 x 71 x 177 mm	129 x 71 x 192 mm	129 x 71 x 237 mm	176 x 95 x 338 mm	176 x 95 x 443 mm
Weight (approx. kg)	0.84	0.99	1,4	3.5	5
Test marks	e-certified (Automotive EMC Directive)			e-certified (Automotive EMC Directive)	
Type of protection	Equivalent to IP 21			Equivalent to IP 21	
 Optional extras					
DC connection cable	–	–	–	9102700005	9102700006
Standard remote control MCR-9	–	–	–	9102600026	9102600026

3.29 // WAECO PocketPower



SI 102
9105303816
12 V DC (11 – 15 V)
230 V AC / modified sine wave $\overline{\square}$
5 V DC, 0.5 A
50 Hz
< 0,4 A
100 W
200 W
–
–
90 %
67 x 43 x 125
282 g
•
–
–
–

3.29 // WAECO PocketPower



PocketPower LC
9102500022
12 V – 24 V DC, 10 A max
12 V / 15 V / 16 V / 18 V (18,5 V) / 19 V (19.5 V) / 20 V / 24 V DC / 90 W max
5 V DC, 2 A
–
–
90 W
–
–
–
–
124.8 x 50 x 31.5
255 g
•
–
–
–

3.28 // WAECO Perfect Battery

Batterielader und Conditioner



	BC 400	BC 100	BR 12
Ref. No.	9103555808	9102500044	9103556045
Input voltage	230 V AC (180 – 253 V)	230 V AC (180 – 253 V)	12 V DC
Input frequency	50 – 60 Hz	50 – 60 Hz	–
Cut-in voltage	–	–	> 12.6 V ± 0.2 V
Stand-by current	–	–	< 0.2 mA
Battery connections	1	1	1
End-of-charging voltage	14.4 V DC	13.8 V DC	–
Float charging voltage	13.7 V DC	13.0 V DC	–
Charging indicator	LED	3 LEDs	–
Maximum battery capacity	100 Ah	–	–
Maximum charging current	2 A/4 A	1.0 A	–
Operating temperature	–20°C to +50°C	–20°C to +50°C	–
Dimensions (W x H x D)	75 x 59 x 140 mm	70 x 100 x 60 mm	100 x 67 x 25 mm
Weight (approx. kg)	0.5	0.45	0.12
Quality features	Overload and short-circuit protection		–
Test mark	–	–	e-certified (Automotive EMC Directive)

WAECO MagicSafe



WAECO MagicTouch



WAECO MagicComfort



WAECO MagicSpeed



WAECO MagicWatch

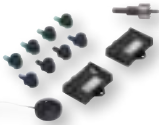

WAECO PerfectView



WAECO BordBar



WAECO CoolFun



Product	Description	Ref. No.	PG	Page
Vehicle accessories				
CAN-BUS Interface				
MagicSpeed CBI 150	CAN bus interface	9101400060	3.06	Page 8
Car alarms / Emergency brake light				
MagicSafe MS660	Comfort car alarm	9101600001	3.08	Page 9
DEFA Security DVS90	CAN bus/Analogue car alarm	611900	3.21	Page 9
MagicSafe ABL 100	Emergency brake light	9101600006	3.08	Page 10
Radio remote control				
MagicTouch MT 200	Car-specific radio remote control	car-specific	3.05	Page 11
MagicTouch MT400	Radio remote control for universal retrofitting	9101300007	3.05	Page 11
Seating comfort				
MagicComfort MCS20	Air-conditioned seat cover, 12 volts	9101700043	3.23	Page 12
MagicComfort MH40S	Heated seat cover, 12 volts	9101700023	3.23	Page 12
MagicComfort MH40GS	Heated seat cover, 12 volts	9101700024	3.23	Page 12
MagicComfort MSH60	Retrofit insert seat heater for two seats	9101700025	3.23	Page 13
MagicComfort MSH601	Retrofit insert seat heater for one seat	9101700026	3.23	Page 13
MagicComfort MSH 300	NEW Retrofit insert seat heater carbon for two seats	9101700034	3.23	Page 13
MagicComfort MSH 301	NEW Retrofit insert seat heater carbon for one seat	9101700035	3.23	Page 13
Cruise controls				
MagicSpeed MS 400	Comfort cruise control, vacuum servo	9103555827	3.06	Page 14
MagicSpeed MS 700	Comfort cruise control, electric servo	9103555851	3.06	Page 14
MagicSpeed MS 50	Standard cruise control for universal use	9103555828	3.06	Page 14
MagicSpeed MS880 *	Comfort cruise control with speed limiter function	9101400069	3.06	** Page 15
* Please note that the vehicle-specific cable set for installation of the MS 880 has to be ordered separately ** without control element see p. 15				
Parking aids				
MagicWatch MWE9008	Parking aid, 8-built-in sensors	9101500055	3.07	Page 19
MagicWatch WPS910	Wireless parking aid for cars, 8 built-in sensors for front and rear	9101500020	3.07	Page 19
MagicWatch MWE820	Parking aid, 4-built-in sensors	9101500040	3.07	Page 20
MagicWatch MWE860	Parking aid, 4-built-in sensors	9101500041	3.07	Page 20
MagicWatch MWE9004	Parking aid, 4-built-in sensors	9101500054	3.07	Page 21
MagicWatch MW650	Parking aid for trucks, 4 sub-mounted sensors	9101555875	3.07	Page 22
MagicWatch MWE650	Parking aid for trucks, 4-built-in sensors	9103555886	3.07	Page 22
MagicWatch MWE890	Parking aid for front bumper	9101500042	3.07	Page 23
MagicWatch WPS 900F	Wireless parking aid for use in the front car bumper	9101500019	3.07	Page 23
Mobile safety solutions				
PerfectView RVS 550	Reversing video system	9101900009	3.19	Page 26
PerfectView RVS 580	Reversing video system	9101900020	3.19	Page 26
PerfectView RVS 530	Reversing video system	9101900034	3.19	Page 27
PerfectView RVS 560	Reversing video system	9101900057	3.19	Page 27
PerfectView MC 402	NEW Moniceiver with 6.2" 2 DIN monitor,	9102100024	3.19	Page 28
PerfectView MC 460	NEW Moniceiver, brake light console with colour cylinder camera	9101900071	3.19	Page 28
PerfectView MC 430	NEW Moniceiver, roof-mount housing with colour ball camera	9101900073	3.19	Page 29
PerfectView RVS 718	NEW Reversing video system	9101900047	3.19	Page 29
PerfectView NAV 760EU	NEW Blaupunkt navigation system with colour cylinder camera	9101900066	3.19	Page 30
PerfectView NAV 730EU	NEW Blaupunkt navigation system with colour ball camera	9101900067	3.19	Page 31
PerfectView NAV 718PH	NEW Blaupunkt navigation system with colour ball camera	9101900063	3.19	Page 31
PerfectView NAV 750PH	NEW Blaupunkt navigation system with colour camera	9101900064	3.19	Page 31
Mobile refrigeration				
Thermoelectric car coolers				
BordBar AS 25	Thermoelectric car cooler	9105302816	4.08	Page 34
BordBar TB 08	Thermoelectric car cooler	9105302016	4.08	Page 34
BordBar TB 15	Thermoelectric car cooler	9105302023	4.08	Page 34
BordBar TE 21 ISO	Thermoelectric car cooler for ISOFIX fastening	9103500528	4.08	Page 35
BordBar TF 08	Thermoelectric car cooler	9105300001	4.08	Page 35
BordBar TF 14	Thermoelectric car cooler	9105302124	4.08	Page 35
Thermoelectric coolers				
CoolFun S28DC	Thermoelectric shopping cool bag	9105302763	4.02	Page 36
CoolFun CX 26	NEW Thermoelectric cooler	9103500871	4.02	Page 36
CoolFun CXT 26	NEW Thermoelectric cooler	9103500873	4.02	Page 36
CoolFun CX 30	NEW Thermoelectric cooler	9103500872	4.02	Page 36
TropiCool TC 07	Thermoelectric cooler	9105302036	4.01	Page 37
TropiCool TC 14FL	Thermoelectric cooler	9105302046	4.01	Page 37
TropiCool TC 21FL	Thermoelectric cooler	9105302085	4.01	Page 37

WAECO CoolFreeze



Product	Description	Ref. No. UK	Ref. No.	PG	Page
Mobile refrigeration					
Thermoelectric cooler					
TropiCool TC 35FL	Thermoelectric cooler		9105302110	4.01	Page 37
Compressor coolers					
CoolFreeze CDF 11	Compressor cooler		9105100007	4.10	Page 38
CoolFreeze CDF 16	NEW Compressor cooler		9105303455	4.10	Page 38
CoolFreeze CDF 18	Compressor cooler		9105100002	4.10	Page 39
CoolFreeze CDF 25	Compressor cooler		9105100003	4.10	Page 39
CoolFreeze CFX 35	Compressor cooler		9105304047	4.30	Page 40
CoolFreeze CFX 40	Compressor cooler		9105304048	4.30	Page 40
CoolFreeze CFX 50	Compressor cooler		9105304049	4.30	Page 41
CoolFreeze CFX 65	Compressor cooler		9105304050	4.30	Page 41
CoolFreeze CFX 65DZ	NEW Compressor cooler		9105304051	4.30	Page 41
CoolFreeze CF 80	Compressor cooler		9105303248	4.10	Page 41
CoolFreeze CF 110	Compressor cooler		9105303102	4.10	Page 41

WAECO PocketPower



Mobile electronics					
Universal laptop charger					
PocketPower LC	Universal laptop charger		9102500022	3.29	Page 43

WAECO PerfectPower



Smart inverter					
PocketPower SI 102	Smart inverter		9105303816	3.29	Page 44

Inverters					
PerfectPower PP 152	Inverter 150 watts, 12 volts	9105303792	9105303791	3.18	Page 45
PerfectPower PP 402	Inverter 350 watts, 12 volts	9105303797	9105303796	3.18	Page 45
PerfectPower PP 602	Inverter 550 watts, 12 volts	9105303802	9105303801	3.18	Page 45
PerfectPower PP 1002	Inverter 1000 watts, 12 volts	9102600003	9102600002	3.18	Page 45
PerfectPower PP 2002	Inverter 2000 watts, 12 volts	9102600005	9102600027	3.18	Page 45

WAECO SinePower



Sine wave inverters					
SinePower MSI 212	Sine wave inverter 150 watts, 12 volts		9102600124	3.30	Page 46
SinePower MSI 412	Sine wave inverter 350 watts, 12 volts		9102600126	3.30	Page 46
SinePower MSI 912	Sine wave inverter 900 watts, 12 volts	9102600033	9102600111	3.30	Page 46
SinePower MSI 1312	Sine wave inverter 1300 watts, 12 volts	9102600035	9102600113	3.30	Page 46
SinePower MSI 1812	Sine wave inverter 1800 watts, 12 volts	9102600037	9102600115	3.30	Page 46
SinePower MSI 1812T	Sine wave inverter 1800 watts, 12 volts	9102600039	9102600117	3.30	Page 46

WAECO PerfectCharge



Battery Chargers					
PerfectCharge MCA 1215	Battery charger, 15 A	9102500046	9102500027	3.16	Page 47
PerfectCharge MCA 1225	Battery charger, 25 A	9102500047	9102500028	3.16	Page 47
PerfectCharge MCA 1235	Battery charger, 35 A	9102500048	9102500029	3.16	Page 47
DEFA SmartCharge	Universal battery charger		701515	3.45	Page 48

WAECO PerfectCharge



Charging converters					
PerfectCharge DC 08	Charging converter 12 volts · 12 volts, 8 A		9102500055	3.16	Page 49
PerfectCharge DC 20	Charging converter 12 volts · 12 volts, 20 A		9102500045	3.16	Page 49
PerfectCharge DC 40	Charging converter 12 volts · 12 volts, 40 A		9102500056	3.16	Page 49

WAECO PerfectBattery



Battery care					
PerfectBattery BC 400	Battery charger and conditioner, 12 volts		9103555808	3.28	Page 50
PerfectBattery BC 100	Battery conditioner, 12 volts		9102500044	3.28	Page 51
PerfectBattery BR 12	Battery refresher, 12 volts		9103556045	3.28	Page 51

WAECO PerfectCoffee



Mobile kitchen					
PerfectCoffee MC01	One-cup coffee maker, 12 volts		9103533009	3.13	Page 53
PerfectCoffee MC01	One-cup coffee maker, 24 volts		9103533010	3.13	Page 53
PerfectKitchen MCK 750	Electric kettle, 12 volts		9103533003	3.14	Page 53
PerfectKitchen MCK 750	Electric kettle, 24 volts		9103533003	3.14	Page 53

WAECO PerfectKitchen



PerfectCoffee MC08	Coffee maker 8 cups, 12 volts		9103533005	3.13	Page 54
PerfectCoffee MC08	Coffee maker 8 cups, 24 volts		9103533002	3.13	Page 54
PerfectCoffee MC05	Coffee maker 5 cups, 12 volts		9103533007	3.13	Page 54
PerfectCoffee MC05	Coffee maker 5 cups, 24 volts		9103533001	3.13	Page 54
PowerVac PV 100	Wet/dry vacuum cleaner		9103500212	3.31	Page 55

DEFA
WarmUp



Vehicle preheating systems					
DEFA SafeStart	Engine heater		car specific	3.11	Page 55
DEFA WarmUp Termini®	NEW Interior heater		car specific	3.11	Page 55
DEFA WarmUp ComfortKit	Engine heater + Interior heater		car specific	3.11	Page 55
DEFA WarmUp Kit	Engine heater + Interior heater + 12-volt battery charger		car specific	3.11	Page 55

Fax order form

Simply copy the form – fill it in – and fax it back to us.

You'll find the fax number of your local sales office on the back page of this catalogue.

Sender details/stamp

2014

Fancy more ...?

New products. New catalogues.



■ "My Freedom"

The specialist catalogue for camping and caravanning. A comprehensive range of products – mobile refrigeration, air conditioning, electronics, reversing video systems, vehicle accessories, lights, windows, awnings, kitchen and sanitation equipment.



■ "More Comfort on Board"

The specialist marine catalogue. Tailor-made comfort solutions for yachts and boats – refrigeration, air conditioning, electronics, power supply, sanitation and galley equipment.



■ "On the Road again"

The tried and tested range of accessories for trucks and trucker. Air conditioning, refrigeration and kitchen equipment, reversing video systems, comfort solutions and electronics.

You can order our catalogues online at www.dometic-waeco.com

What else can we do for you?

The friendly Dometic WAECO team are always glad to help.

If you are interested in our products, but still have some questions you'd like to ask or perhaps you need advice on a product you've just bought, then please get in touch. Fun and convenience for mobile people is our philosophy. Buying one of our products is just the start. Our aim is for you to enjoy a whole range of mobile technology in the future.

You'd like to find out more? Just order the comprehensive catalogues.

Your contact to Dometic WAECO:

www.dometic-waeco.com

info@dometic-waeco.com

Always a good link: the Dometic WAECO website. That's where you will find the complete Dometic WAECO range. You'll get a clear view of the products along with detailed information. Plus interesting news about our company and the latest special offers and of course you can order all our catalogues online.



Dometic GROUP is a customer-driven, world-leading provider of leisure products for the RV, automotive, truck and marine markets. We supply the industry and aftermarket with a complete range of air conditioners, refrigerators, awnings, cookers, sanitation systems, lighting, mobile power equipment, comfort and safety solutions, windows, doors and other equipment that make life more comfortable away from home.

Dometic GROUP supplies a wide range of workshop equipment for service and maintenance of built-in air conditioners.

Dometic GROUP also provides specially designed refrigerators for hotel rooms, offices, wine storage and transport and storage of medical products.

Our products are sold in almost 100 countries and are produced mainly in wholly-owned production facilities around the world.

THE COMPREHENSIVE ACCESSORY RANGE FOR CARS & VANS



GERMANY

Dometic WAECO International GmbH
Hollefeldstraße 63
D-48282 Emsdetten
Tel +49 (0) 2572 879-0
Fax +49 (0) 2572 879-300
Mail info@dometic-waeco.de
Net www.dometic-waeco.de

UNITED KINGDOM

Dometic UK Ltd.
Dometic House, The Brewery,
Blandford St. Mary
Dorset DT11 9LS
Tel +44 844 626 0133
Fax +44 844 626 0143
Mail automotive@dometic.co.uk
Net www.dometic-waeco.com

AUSTRALIA

Dometic Australia Pty. Ltd.
1 John Duncan Court
Varsity Lakes QLD 4227
Tel +61 7 55076000
Fax +61 7 55076001
Mail sales@dometic-waeco.com.au

AUSTRIA

Dometic Austria GmbH
Neudorferstrasse 108
A-2353 Guntramsdorf
Tel +43 2236 908070
Fax +43 2236 90807060
Mail info@waeco.at

BENELUX

Dometic Benelux B.V.
Ecustraet 3
NL-4879 NP Etten-Leur
Tel +31 76 5029000
Fax +31 76 5029019
Mail info@dometic.nl

Dometic Branch Office Belgium

Zinkstraat 13
B-1500 Halle
Tel +32 2 3598040
Fax +32 2 3598050
Mail info@dometic.be

BRAZIL

Dometic DO Brasil LTDA
Avenida Paulista 1754, conj. 151
SP 01310-920 Sao Paulo
Tel +55 11 3251 3352
Tel +55 11 3251 3362
Mail info@dometic.com.br

DENMARK

Dometic Denmark A/S
Nordensvej 15, Taulov
DK-7000 Fredericia
Tel +45 75585966
Fax +45 75586307
Mail info@dometic.dk

FINLAND

Dometic Finland OY
Mestarintie 4
FIN-01730 Vantaa
Tel +358 20 7413220
Fax +358 9 7593700
Mail info@dometic.fi

FRANCE

Dometic France SAS
ZA du Pré de la Dame Jeanne
B.P. 5
F-60128 Plailly
Tel +33 3 44633525
Fax +33 3 44633518
Mail automotive@dometic.fr

HONG KONG

Dometic Group Asia Pacific
Suites 2207-11, 22/F, Tower 1
The Gateway, 25 Canton Road
Tsim Sha Tsui, Kowloon
Tel +852 2 4611386
Fax +852 2 4665553
Mail info@waeco.com.hk

HUNGARY

DOMETIC PLC. SALES OFFICE
H-1147 Budapest
Kerékgyártó u. 5.
Tel +36 1 468 4400
Fax +36 1 468 4401
Mail budapest@dometic.hu

ITALY

Dometic Italy S.r.l.
Via Virgilio, 3
I-47122 Forlì (FC)
Tel +39 0543 754901
Fax +39 0543 754983
Mail vendite@dometic.it

JAPAN

Dometic KK
Maekawa-Shibaura, Bldg. 2
2-13-9 Shibaura Minato-ku
Tokyo 108-0023
Tel +81 3 5445 3333
Fax +81 3 5445 3339
Mail info@dometic.jp

MEXICO

Dometic AB
Circuito Médicos No. 6 Local 1
Colonia Ciudad Satélite
CP 53100 Naucalpan de Juárez
Estado de México
Tel +52 55 5374 4108
Tel +52 55 5374 4106
Fax +52 55 5393 4683
Mail info@dometic.com.mx

NEW ZEALAND

Dometic New Zealand Ltd.
Unit E, The Gate
373 Neilson Gate
Penrose 1061, Auckland
Tel +64 9 622 1490
Fax +64 9 622 1573
Mail customerservices@dometic.co.nz

NORWAY

Dometic Norway AS
Østerøyvelen 46
N-3236 Sandefjord
Tel +47 33428450
Fax +47 33428459
Mail firmapost@dometic.no

POLAND

Dometic Poland Sp. z o.o
ul. Pulawska 435A
PL-02-801 Warszawa
Tel +48 22 414 3200
Fax +48 22 414 3201
Mail info@dometic.pl

PORTUGAL

Dometic S.L.- Sucursal em Portugal
Beloura Business Center
Rua dos Navegantes, Bloco 3, 1ªA
2710-297 Sintra
Tel +351 219 244 173
Fax +351 219 243 206
Mail info@dometic.pt

RUSSIA

Dometic RUS LLC
Komsomolskaya square 6 – 1
RU-107140 Moscow
Tel +7 495 780 79 39
Fax +7 495 916 56 53
Mail info@dometic.ru

SINGAPORE

Dometic Pte Ltd
18 Boon Lay Way 06-140 Trade Hub 21
Singapore 609966
Tel +65 6795 3177
Fax +65 6862 6620
Mail dometic@dometic.com.sg

SLOVAKIA

Dometic Slovakia s.r.o
Tehelná 8
SK-98601 Filakovo
Tel +421 47 4319 100
Fax +421 47 4319 133
Mail dometic@dometic.sk

SOUTH AFRICA

Dometic (Pty) Ltd.
Regional Office
South Africa & Sub-Saharan Africa
P.O. Box 2562
2008 Bedfordview
Tel +27 11 4504978
Fax +27 11 4504976
Mail info@dometic.co.za

SPAIN

Dometic Spain S.L.
Avda. Sierra del Guadarrama, 16
E-28691 Villanueva de la Cañada
Madrid
Tel +34 902 111 042
Fax +34 900 100 245
Mail info@dometic.es

SWEDEN

Dometic Scandinavia AB
Gustaf Melins gata 7
S-421 31 Västra Frölunda
Tel +46 31 7341100
Fax +46 31 7341101
Mail info@dometicgroup.se

SWITZERLAND

Dometic Switzerland AG
Riedackerstrasse 7a
CH-8153 Rümlang
Tel +41 44 8187171
Fax +41 44 8187191
Mail info@dometic-waeco.ch

UNITED ARAB EMIRATES

Dometic Middle East FZCO
P.O. Box 17860
S-D 6, Jebel Ali Freezone
Dubai
Tel +971 4 883 3858
Fax +971 4 883 3868
Mail info@dometic.ae

Your dealer:

